

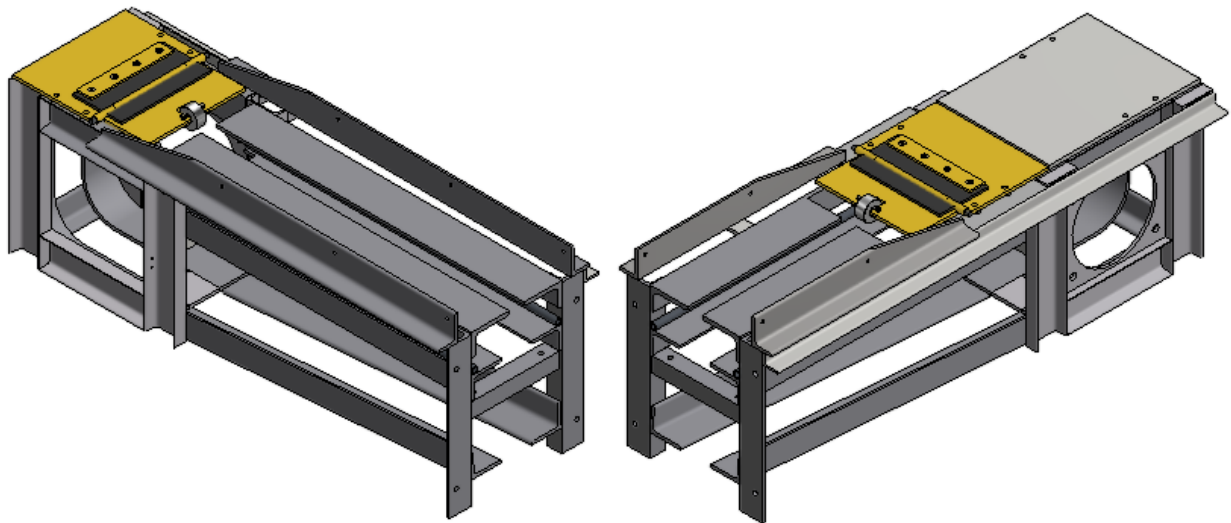

# Heco Conversion Kit™



**BEFORE**

**AFTER**

## Installation Manual

Sonny's Enterprises, Inc.  
5605 Hiatus Road  
Tamarac, FL 33321  
13v1



## **\*Table of Contents\***

<b>*WARNING SAFETY REQUIREMENTS*</b> .....	<b>3</b>
<b>*INTRODUCTION*</b> .....	<b>5</b>
<b>*INSTALLATION*</b> .....	<b>6</b>
<b>*WARRANTY*</b> .....	<b>14</b>
<b>*CUSTOMER SERVICE*</b> .....	<b>15</b>



# **\*WARNING SAFETY REQUIREMENTS\***

1. All employees must be thoroughly trained in safe operation and standard maintenance practices. All employees must review this entire manual monthly.
2. Do not enter the wash tunnel when the equipment is operating. Death or dismemberment may occur.
3. Do not wear loose fitting clothing or jewelry around moving equipment. Do not allow any part of your body or other objects (including ladders, hoses or tools) to come in contact with moving equipment. Entanglement may result causing death or dismemberment.
4. Do not leave a ladder or any other items such as wash down hoses or tools in the wash tunnel while equipment is running. Vehicle damage and injury, including death, can occur.
5. Always exercise caution when walking (never run) through the wash tunnel as there may be slippery conditions. Be careful so you do not bump into or trip over equipment.
6. Only those employees specifically instructed and trained by the location management are permitted to enter the wash tunnel to perform inspections or maintenance. At least two qualified maintenance people must be present when performing equipment repairs or preventive maintenance.
7. Do not perform any maintenance or work on equipment unless you first perform Lock-Out Safety Precautions. All electrically powered equipment must have manually operated disconnects capable of being locked in the "OFF" position. Equipment that has been "locked out" for any reason must be restarted only by the person who performed the "lock out" operation.
8. When working on any equipment that is higher than your shoulders, always use a fiberglass ladder that is in good condition.
9. Do not attempt to repair or adjust any pressurized liquid or pneumatic part, hose, pipe or fitting while that equipment is in operation.
10. Electrical connections and repairs must be performed by a Licensed Electrician Only.
11. Emergency "STOP" buttons must be well marked and their location and proper use reviewed with all personnel. Any activated "STOP" button must be reset only by the person who activated it. Clear the wash tunnel of any people, ladders, hoses, tools and other loose items before restarting the equipment. An audible device must sound to warn people that the equipment is starting.
12. Do not operate any piece of equipment that requires safety covers with those covers removed or improperly installed. Do not operate any piece of equipment if any component of that piece is suspected to be defective or malfunctioning.



## Equipment Program - Manuals Heco Conversion Kit™

13. Store all cleaning and washing solutions and oils in a well-ventilated area. Clean up fluid spills immediately to prevent hazardous safety conditions. Be certain to follow all safety procedures on MSDS Sheets for each chemical product used.
14. All hydraulic and electric systems in the wash tunnel equipped with a torque relief or overload should be checked and set at the minimum amount that will allow for proper functionality under normal washing conditions.
15. No unauthorized people should ever be permitted in the wash tunnel or near the equipment at any time.

\* \* \*

### **!! CAUTION !!**

When a piece of equipment must be in operation during inspection or maintenance, one qualified technician must stay at the power disconnect switch while another qualified technician performs the inspection or maintenance.



## **\*INTRODUCTION\***

This Owner's Manual contains information that is vital to the successful installation, operation and maintenance of your SONNY'S vehicle washing equipment.

Please read, and understand, the full contents of this manual before installation and operation of the equipment. Keep this booklet in a location where it may be used for ongoing reference.

Should you have any questions on the operation or servicing of this equipment please contact

**TECHNICAL SERVICES DEPT.**

**SONNY'S ENTERPRISES INC.**

**5605 Hiatus Road**

**TAMARAC, FLORIDA 33321**

**TELEPHONE: 800-327-8723    FAX: 800-495-4049**



## \*INSTALLATION\*

Step 1: Remove Exit Door Assembly and place it off to the side as it will be reused.

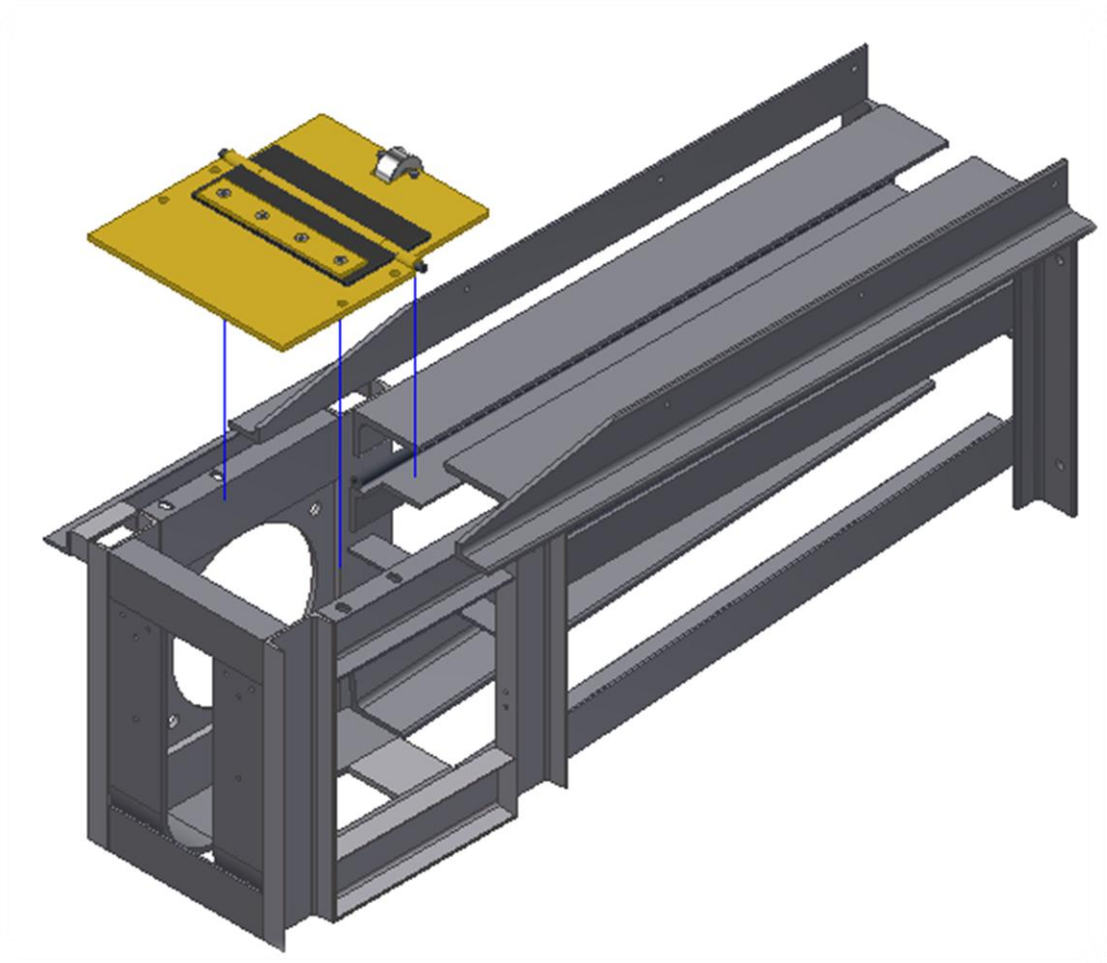



## Equipment Program - Manuals Heco Conversion Kit™

Step 2: Bolt on the Conveyor Plate using the hardware supplied in the conversion kit as shown below.

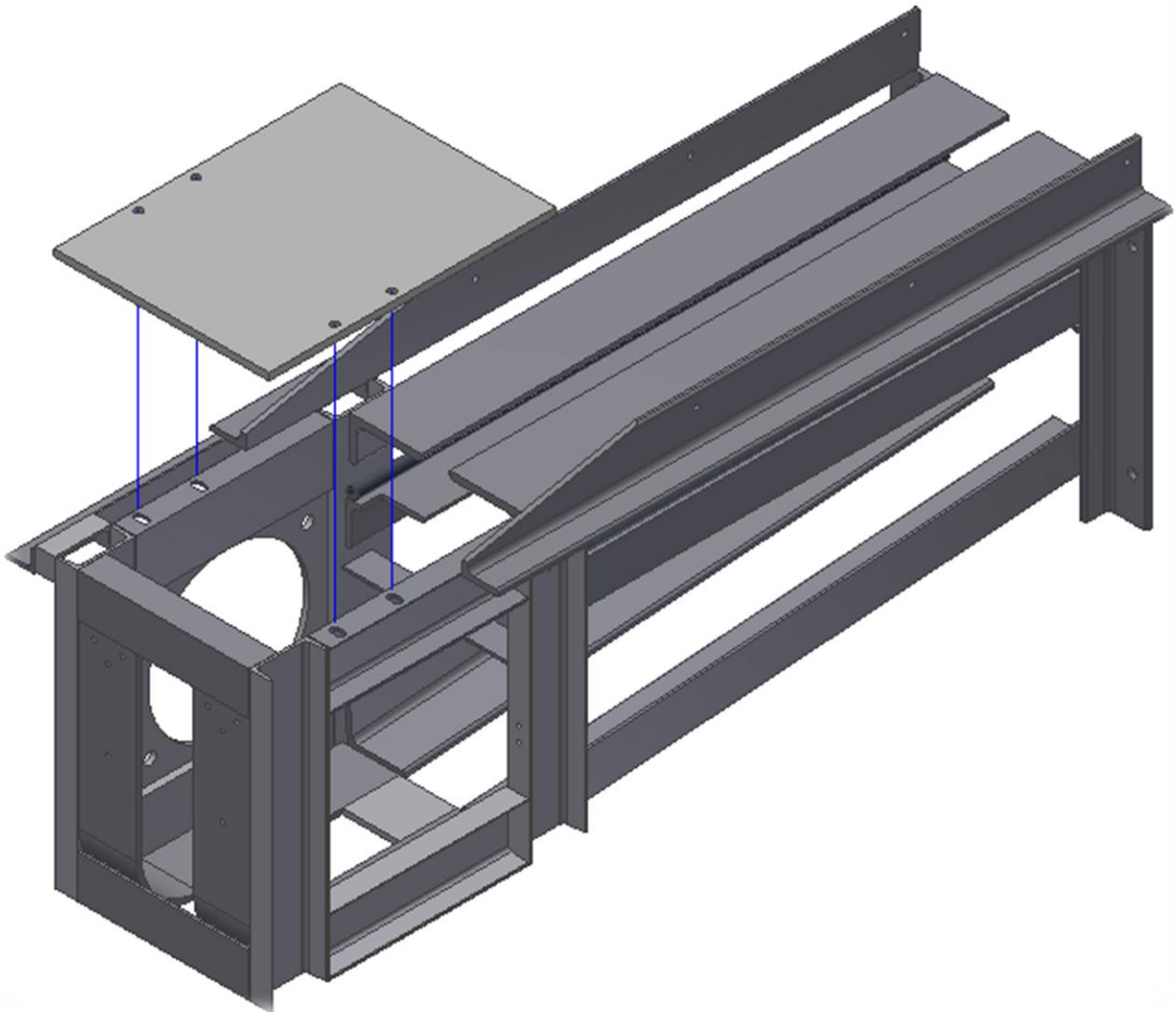



## Equipment Program - Manuals Heco Conversion Kit™

Step 3: Grind off welds on both side of the conveyor and remove the first angle as shown below.

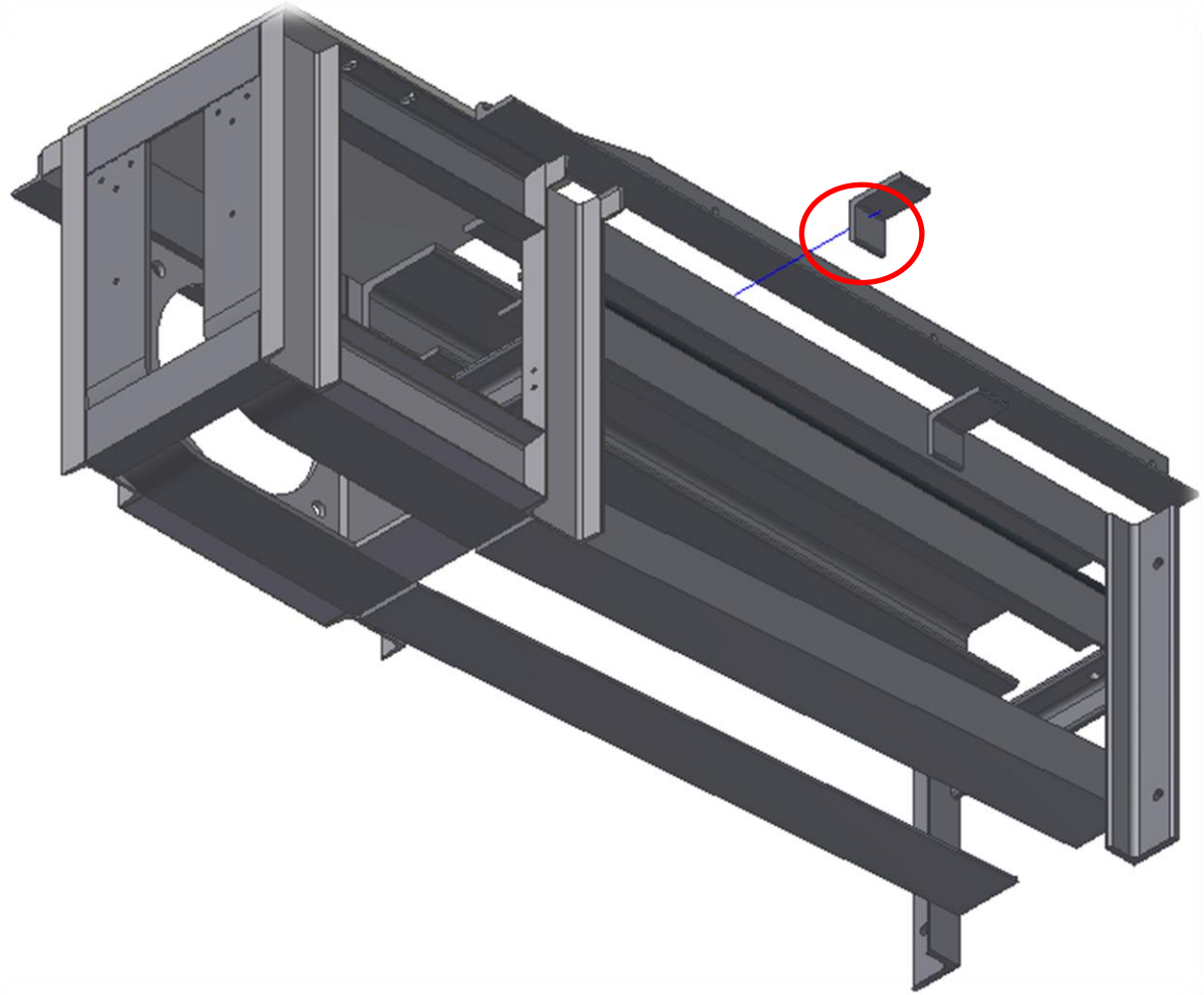



Step 4: Locate the door and remove pin and disassemble door as shown. Place the door flush against the Conveyor Plate previously added. See diagram below.

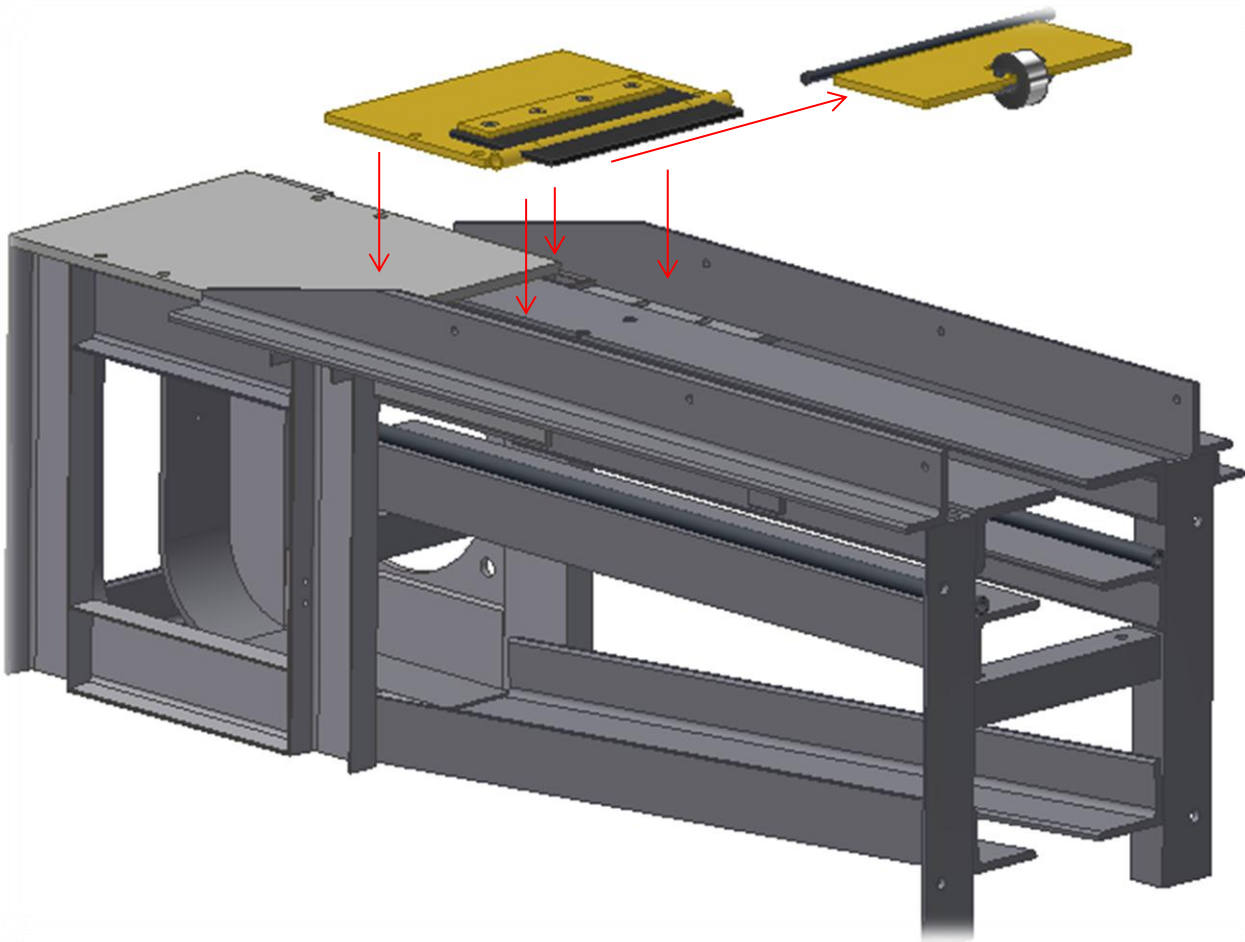



## Equipment Program - Manuals Heco Conversion Kit™

Step 5: Bolt the angles provided loosely to the exit door. Once the bolts are tight so the plate can't shift, tack the angles in place. Remove door and weld angles.

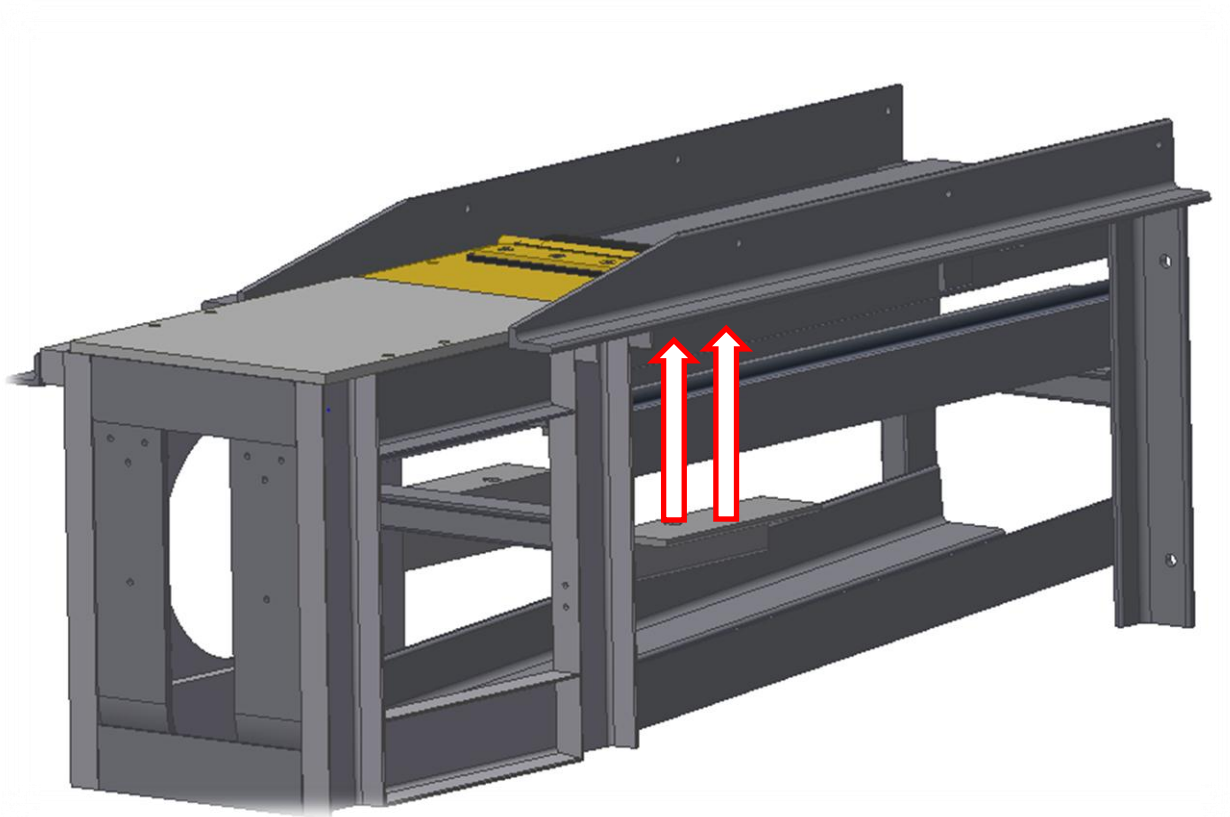

Step 6: Using a grinder or torch create cut outs as shown below. Grind any rough edges until smooth. The notch on the left provides clearance for the bolts and nuts on door assembly. The notch on the right side allows the rollers to drop back down.

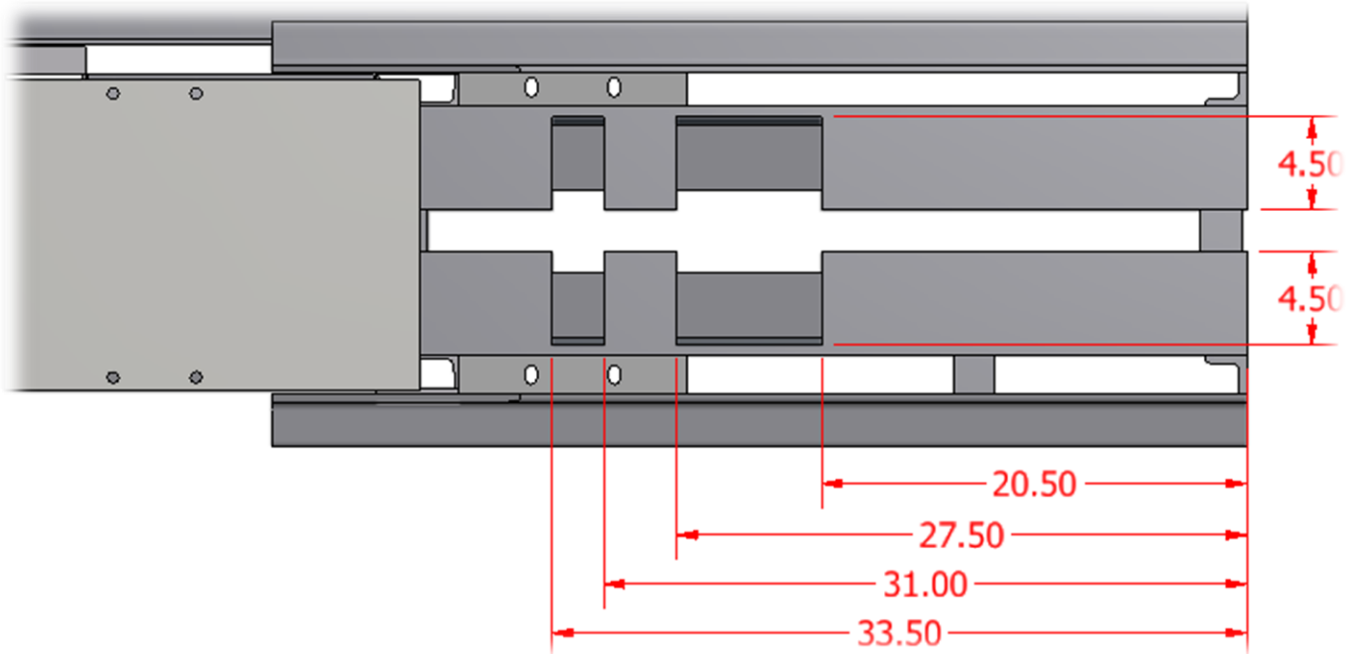



## Equipment Program - Manuals Heco Conversion Kit™

Step 7: Modify DS and PS angles as shown below using a grinder or torch. Ensure all edges are ground smooth.

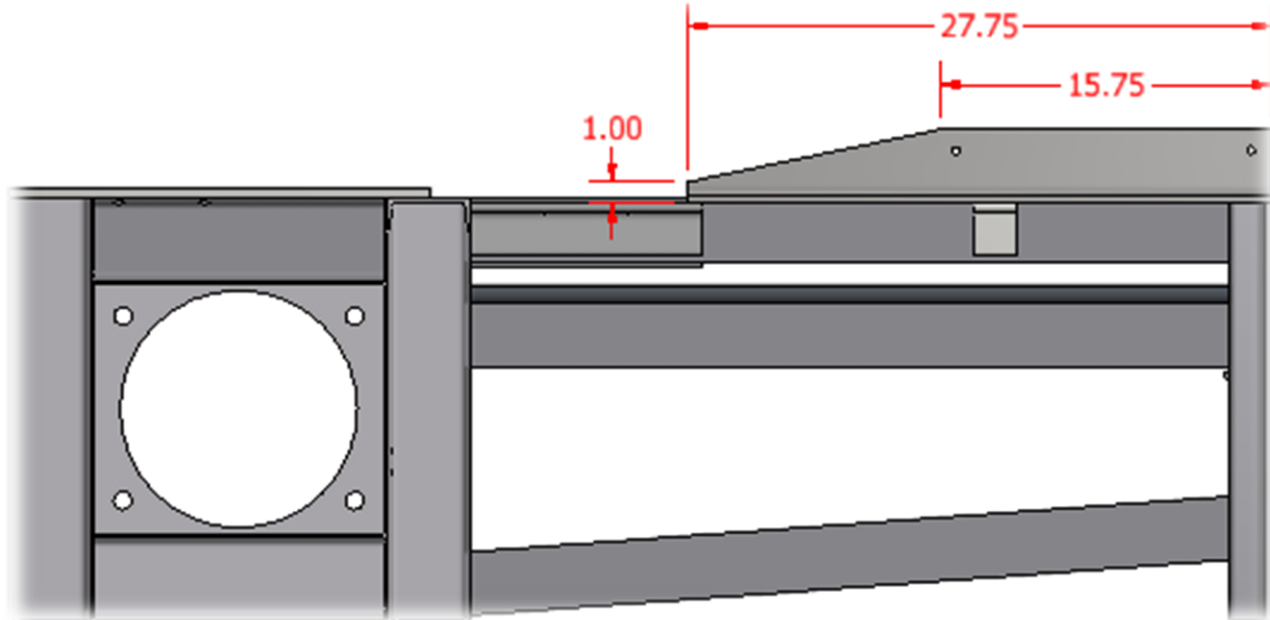

Step 8: Re-assemble the door and bolt securely back onto the frame. Test a few rollers to ensure smooth operation and no jams.

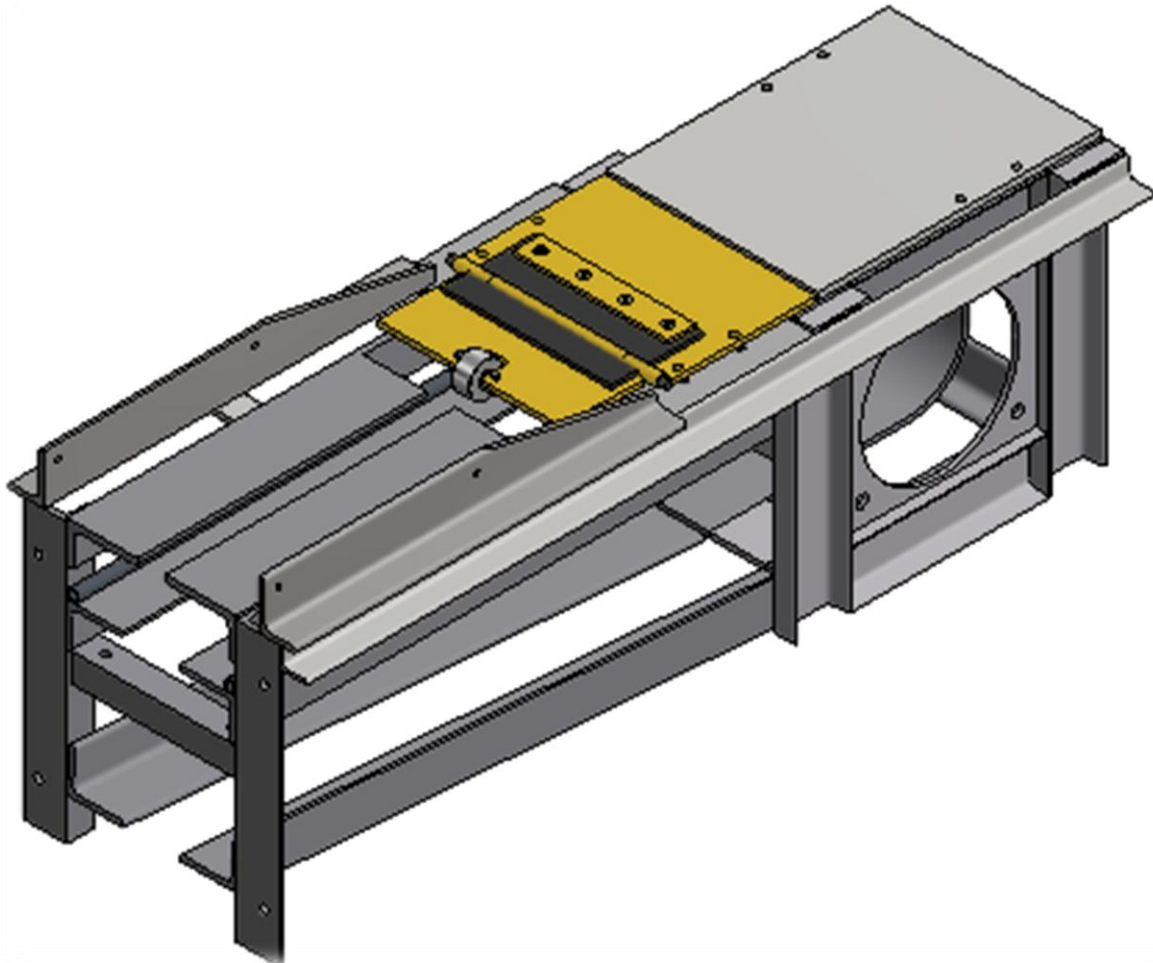



## \*WARRANTY\*

### SONNY'S ENTERPRISES, INC. FACTORY LIMITED LIFETIME WARRANTY

Equipment manufactured by SONNY'S ENTERPRISES, INC. is warranted to be free from defect in material and workmanship. Welded metal framework and other non-moving, non-wearable fabricated metal components manufactured by SONNY'S are warranted for the life of the equipment to the original purchaser. Fabricated metal wearable surface and moving components manufactured by SONNY'S are warranted for a period of two (2) years to the original purchaser of the equipment.

All components assembled to SONNY'S equipment that are manufactured by others will also be warranted by SONNY'S for a period of two (2) years to the original purchaser of the equipment. Chain and rollers are not included in the extended 2 year warranty. All new PermaColor™ cloth shipped with new SONNY'S equipment is warranted for a period of one (1) year, or 100,000 Car Washes, whichever occurs first. All new MicroClean™ Wash Material shipped with new SONNY'S equipment is warranted for a period of one (1) year, or 60,000 Car Washes, whichever occurs first.

This warranty is not assignable or transferable. The warranty period begins the first day following installation or 30 days from the original invoice date, whichever occurs first. The Seller's liability shall be limited to repair or replacement of materials found to be defective within the warranty period. In the event of repair or replacement this limited warranty is noncumulative. The Purchaser must supply the Seller with immediate written notice when any defects are found. The Seller shall have the option of requiring the return of defective material to establish the Purchaser's claim. Neither labor nor transportation charges are included in this warranty. Transportation damage claims are to be submitted to the carrier of the damaged materials.

This warranty is based upon the Purchaser's reasonable care and maintenance of the warranted equipment. It does not apply to any equipment which has been subject to misuse, including neglect, accident or exposure to harsh chemicals, including but not limited to Hydrofluoric Acid • Ammonium Bi-fluoride • Bromic Acid • Muriatic Acid • Sulfonic Acid • Phosphoric Acid • Hydrogen Cyanide • Hydrochloric Acid • Chlorinated Solvents . Nor does it apply to any equipment which has been repaired or altered by anyone not so authorized by SONNY'S. Further, the equipment must be properly installed with proper accuracy of all specified plumbing, electrical, and mechanical requirements. This warranty does not apply to normal wear and tear or routine maintenance components.

EXCEPT AS EXPRESSLY STATED HEREIN, SONNY'S SHALL NOT BE LIABLE FOR DAMAGES OF ANY KIND IN CONNECTION WITH THE PURCHASE, MAINTENANCE, OR USE OF THIS EQUIPMENT INCLUDING LOSS OF PROFITS AND ALL CLAIMS FOR CONSEQUENTIAL DAMAGES. THE LIMITED WARRANTY EXPRESSED HEREIN IS IN LIEU OF ALL OTHER WARRANTIES EXPRESSED OR IMPLIED. SONNY'S NEITHER ASSUMES NOR AUTHORIZES ANY PERSON TO ASSUME FOR IT ANY OTHER OBLIGATION OR LIABILITY IN CONNECTION HEREWITH.



## \*CUSTOMER SERVICE\*

Please contact SONNY'S Equipment Department for installation and/or operational questions regarding this piece of equipment.

Please refer to the Parts list in this manual or our Parts Catalog and contact SONNY'S Customer Service Order Entry Department for any replacement parts for this piece of equipment.

For Equipment Repair Manuals please visit the web at [www.sonnysdirect.com/manuals](http://www.sonnysdirect.com/manuals)

DEPARTMENT	PHONE NUMBERS	FAX NUMBERS
Toll Free Main Line	800-327-8723	800-495-4049
Equipment Department	954-720-4100	954-720-9292

Or you can email Sales at [sales@sonnysdirect.com](mailto:sales@sonnysdirect.com)

*Thank you for being a SONNY'S car wash equipment owner!*

*From all of us here at*

