

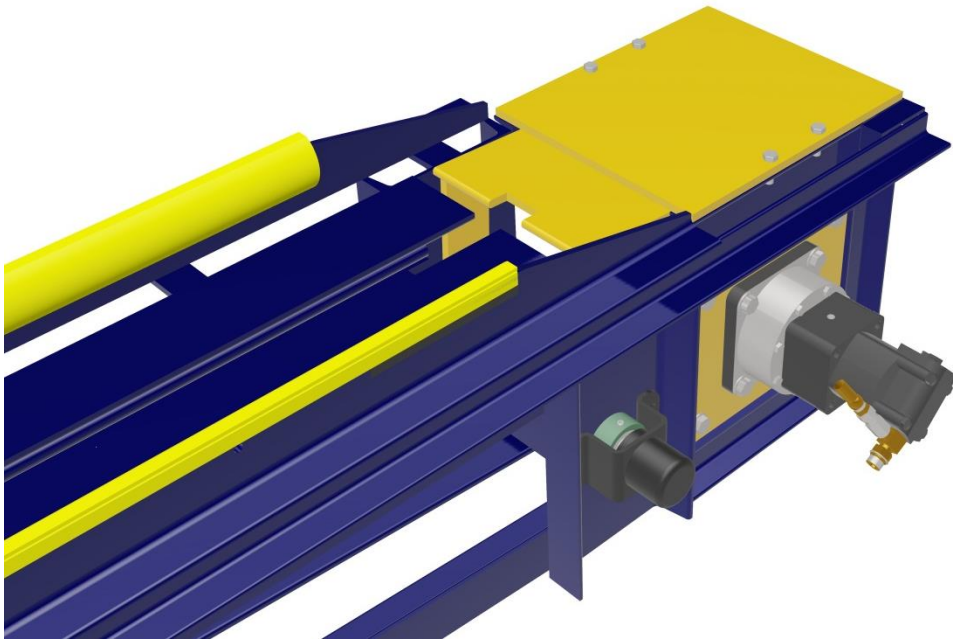

# Over-Under Conveyor Soft-Drop



## Owner's Manual

Sonny's Enterprises, Inc.  
5605 Hiatus Road  
Tamarac, Florida 33321



# \*Table of Contents\*

**WARNING \*SAFETY REQUIREMENTS\* WARNING .....3**

**\*INTRODUCTION\* .....5**

    Product Specifications.....6

    Optional Related Equipment .....7

**\*INSTALLATION\* .....8**

    Preparation of Concrete .....8

    Utilities Requirements .....9

    Dimensions .....10

    Equipment Installation .....14

        Conveyor Installation .....14

    Adjustments and Testing.....22

    Chain Tension Adjustment - Spring.....24

    Chain Tension Adjustment - Air.....25

**\*GENERAL OPERATION\* .....26**

**\*PREVENTIVE MAINTENANCE\* .....27**

**\*EXPLODED VIEWS\* .....29**

**\*PARTS LIST\* .....35**

**\*WARRANTY\* .....45**

**\*CUSTOMER SERVICE\* .....46**

Sonny's and Sonny's The CarWash Factory are Registered trademarks of Sonny's Enterprises LLC  
 Make CarWashing Easy and OneWash are trademarks of Sonny's Enterprises LLC  
**Designed** here. **Built** here. **Backed** here. is a trademark of Sonny's Enterprises LLC  
 Products mentioned herein are for identification purposes only and may be registered trademarks of their respective companies.  
 All other brand names, trademarks or registered trademarks are the property of their respective owners.



## **WARNING \*SAFETY REQUIREMENTS\* WARNING**

1. All employees must be thoroughly trained in safe operation and standard maintenance practices. All employees must review this entire manual monthly.
2. Do not enter the wash tunnel when the equipment is operating. Death or dismemberment may occur.
3. Do not wear loose fitting clothing or jewelry around moving equipment. Do not allow any part of your body or other objects (including ladders, hoses, or tools) to come in contact with moving equipment. Entanglement may result causing death or dismemberment.
4. Do not leave a ladder or any other items such as wash down hoses or tools in the wash tunnel while equipment is running. Vehicle damage and injury, including death, can occur.
5. Always exercise caution when walking (never run) through the wash tunnel as there may be slippery conditions. Be careful so you do not bump into or trip over equipment.
6. Only those employees specifically instructed and trained by the location management are permitted to enter the wash tunnel to perform inspections or maintenance. At least two qualified maintenance people must be present when performing equipment repairs or preventive maintenance.
7. Do not perform any maintenance or work on equipment unless you first perform Lock-Out Safety Precautions. All electrically powered equipment must have manually operated disconnects capable of being locked in the "OFF" position. Equipment that has been "locked out" for any reason must be restarted only by the person who performed the "lock out" operation.
8. When working on any equipment that is higher than your shoulders, always use a fiberglass ladder that is in good condition.
9. Do not attempt to repair or adjust any pressurized liquid or pneumatic part, hose, pipe or fitting while that equipment is in operation.
10. Electrical connections and repairs must be performed by a Licensed Electrician Only.
11. Emergency "STOP" buttons must be well marked and their location and proper use reviewed with all personnel. Any activated "STOP" button must be reset only by the person who activated it. Clear the wash tunnel of any people, ladders, hoses, tools, and other loose items before restarting the equipment. An audible device must sound to warn people that the equipment is starting.
12. Do not operate any piece of equipment that requires safety covers with those covers removed or improperly installed. Do not operate any piece of equipment if any component of that piece is suspected to be defective or malfunctioning.



## Owner's Manual Over-Under Conveyor Soft-Drop

13. Store all cleaning and washing solutions and oils in a well-ventilated area. Clean up fluid spills immediately to prevent hazardous safety conditions. Be certain to follow all safety procedures on MSDS Sheets for each chemical product used.
14. All hydraulic and electric systems in the wash tunnel equipped with a torque relief or overload should be checked and set at the minimum amount that will allow for proper functionality under normal washing conditions.
15. No unauthorized people should ever be permitted in the wash tunnel or near the equipment at any time.

\* \* \*

### !! CAUTION !!

When a piece of equipment must be in operation during inspection or maintenance, one qualified technician must stay at the power disconnect switch while another qualified technician performs the inspection or maintenance.



## **\*INTRODUCTION\***

This Manual contains information that is vital to the successful installation, operation and maintenance of your SONNY'S vehicle washing equipment.

Please read, and understand, the full contents of this manual before installation and operation of the equipment. Keep this booklet in a location where it may be used for ongoing reference.

Should you have any questions on the operation or servicing of this equipment please contact:

**TECHNICAL SERVICES DEPT.**

**SONNY'S ENTERPRISES INC.**

**5605 Hiatus Road**

**TAMARAC, FLORIDA 33321**

**TELEPHONE: 800-327-8723    FAX: 800-495-4049**

**THANK YOU FOR YOUR CONFIDENCE IN SONNY'S !!!!**



**Designed here. Built here. Backed here.™**



## Product Specifications

- Accepts 13 inch wide tires.
- Rubber pads placed in strategic positions to help reduce operations noise.
- Direct drive speed reducer driven by high torque hydraulic motor.
- Available in electric drive.
- Removable cover on Take-Up section for ease of maintenance.
- Reliable spring loaded Take-Up standard, and optional air shock system available.
- Long lasting SC78 conveyor chain is standard, optionally Log, X458 or D88K chains are also available.
- 7 ft. 4 in. roller spacing standard, optionally 3 ft. 6 in. roller spacing available.
- 6 wheel mid-profile UHMW roller assemblies are standard, available low and tall profile rollers are also available.
- 1/2 inch thick steel on top deck and 3/8 inch thick steel on all other levels. Also available in stainless steel.
- Double hinged exit pusher roller door.
- UHMW protective covering for the guide rails.
- Air cylinder controlled roller-up fork.
- Solid state pulse switch kit available.
- Safety horn warning kit available.
- Tracking bars and Kick off plate must be used with all Front Wheel Pull (FWP) installation.

## Optional Related Equipment



**SONNY'S** Over-Under Conveyor

### Problem

You need a conveyor that you never need to think about, that is easy to maintain, and delivers unparalleled safety and reliability.

### Solved

Refined over 25 years, SONNY'S Banana Peel Rail Conveyor is a perfect example of simplicity at its best. Ultra-safe, slippery, half-round UHMW on both rails of the conveyor make this reliable workhorse safer than ever before. Easily accommodating today's low profile tires, wide rims, and all-wheel-drive vehicles, this latest rendition of our over-under conveyor guides even the most poorly aligned vehicles straighter than ever before in either rear-wheel-push OR front-wheel-pull configuration. Available with electric or hydraulic drive system, air or spring take-up, and painted or galvanized finish, SONNY'S Banana Peel Conveyor is engineered to deliver years of trouble-free operation.

ELECTRIC  
HYDRAULIC



### Standard Features

- Anti-jam roller guides
- Exposed grease fittings for easy application
- Easy maintenance through access doors
- Durable 1/2in thick top deck & 3/8in steel frame
- Reliable chain guides included (#20005397)
- Take-up idler sprocket or drum
- Roller-down door is 3/8in steel with heavy-duty rubber hinge
- Exclusive double roller take-up bearings
- 1 1/2in stainless steel take-up adjustment shaft with UHMW poly bushings
- Heco direct-drive gear box available with electric or hydraulic motor
- **Banana Peel UHMW rail system**

### Choose Your Finish



**Painted Conveyor**  
Standard surface delivers excellent corrosion resistance at an affordable price.

or



**Galvanized Conveyor**  
Optional surface coating can add years of life to your conveyor frame.

### Choose Your Drive



**Hydraulic Drive**  
Simple, safe, and durable choice for wet environment applications.

or



**Electric Drive**  
Reduce utility consumption and eliminate the potential for hydraulic leaks.

### Choose Your Take-Up



**Spring Take-up**  
Long time industry standard for durability and reliability.

or



**Air Take-up**  
Automatically adjusts to keep proper tension and easily releases for maintenance.

### Choose Your Chain



**Log Chain**  
- Most durable  
- Remove links without tools  
- Easiest to maintain



**X-458**  
- Remove links without tools



**SC78**  
- Is the durable industry standard  
- Compatible with older style D88K Chain



**D88K**  
- Self-locking chain



# **\*INSTALLATION\***

## **Preparation of Concrete**

**THE MOST IMPORTANT FACTOR IN SUCCESSFUL CONVEYOR OPERATION IS ACCURATE CONCRETE WORK ON THE WASH TUNNEL FLOOR !!!**

Faithful adherence to the specifications shown on SONNY'S drawings #CWS-SC-01 and #CWT-SC-98004-A3 will help to achieve this goal! While all dimensions and features shown on these drawings are very important some key factors require special attention:

1. For a standard trench using REAR WHEEL PUSH Conveyors the concrete shelf for the conveyor track must be 19 3/4 inches BELOW the finished floor elevation. (Ref. Section Thru Trench detail "E" Dwg. #CWS and #CWT)
2. For a standard trench using FRONT WHEEL PULL Conveyors the concrete shelf for the conveyor track must be 21 3/4 inches BELOW the finished floor elevation. (Ref. Section Thru Trench detail "E" Dwg. #CWS and #CWT)
3. For a self-cleaning trench Conveyors the concrete shelf for the conveyor track must be 24 inches BELOW the finished floor elevation for FWP and RWP. (Ref. Section Thru Trench detail "E" Dwg. #CWS and #CWT)
4. The width of the conveyor track shelf must be 20 inches and level from side to side. (Ref. Section Thru Trench detail Dwg. #CWS).
5. Proper placement of Customer supplied steel angle and flat plate as shown in Section Thru Trench detail Drawing #CWS.
6. The vertical wall adjoining the conveyor shelf must be plumb to the shelf itself with no bulges (Ref. Section Thru Trench detail dwg. #CWS).
7. The side to side slopes and level areas of the finished floor. (Ref. section thru trench detail Dwg. #CWS and #CWT).
8. The entrance to exit finished floor and conveyor track shelf entrance to exit slope should RISE 3/16 inch per 10 feet of conveyor length, or 1 inch for every 50 ft of length.
9. The wash water and rinse water drain slopes and drain lines are shown in Drawing #CWT. Minimum depth of the water trench is to be 8 inches below the Conveyor track shelf.
10. Be certain that all Notes shown on Drawings #CWS and #CWT are understood and performed properly.
11. Confirm the location of all in-ground chases and conduits as well as required dimensions and slopes prior to pouring concrete.





## Utilities Requirements

**Utilities interconnection and the materials required for interconnection to Sonny's equipment are the responsibility of the customer!**

**Perform all trades work to all applicable local and national codes!**

### Electric

- The Customer's Electrician is to provide and install three #16AWG wires from the tunnel equipment controller to a pulse sensor switch located in the drive section of the conveyor or to an optional remote pulse switch.
- The Customer's Electrician is to provide and install two #16AWG wires from a 120VAC or 24VAC (specify with order) power source through the remote "Roller Up" control switch to the air solenoid valve or to the tunnel equipment controller.
- The Customer's Electrician is to provide and install two #16AWG wires from the tunnel equipment controller to an optional anti-jam switch located in the Take-Up section of the conveyor.
- The Customer's Electrician is to provide and install single phase power through the conveyor interlock circuit for the Horn Warning Kit and/or the Anti-Collision Control Kit. Reference the electrical schematic for the Horn Warning Kit and the electrical diagram with the Anti-Collision Kit.
- Where applicable, the Customer's Electrician is to provide materials and install 208VAC or 230VAC or 460VAC, 3-phase, 60Hz power to the electric motor on the hydraulic power pack or VFD panel from a properly sized three pole circuit breaker and motor starter with three thermal overloads.

### Pneumatic

- The Customer's Plumber is to provide and install a 3/8 inch compressed air line (100PSI @ 0.5CFM) from the air compressor to the air distributor or to the regulator/solenoid manifold for the air cylinder on the conveyor Take-Up section.
- The Customer's Plumber is to provide and install a 3/8 inch compressed air line (100PSI @ 0.5CFM) from the air compressor to the air distributor or to the regulator/solenoid manifold for the optional air Take-Up.

# Dimensions

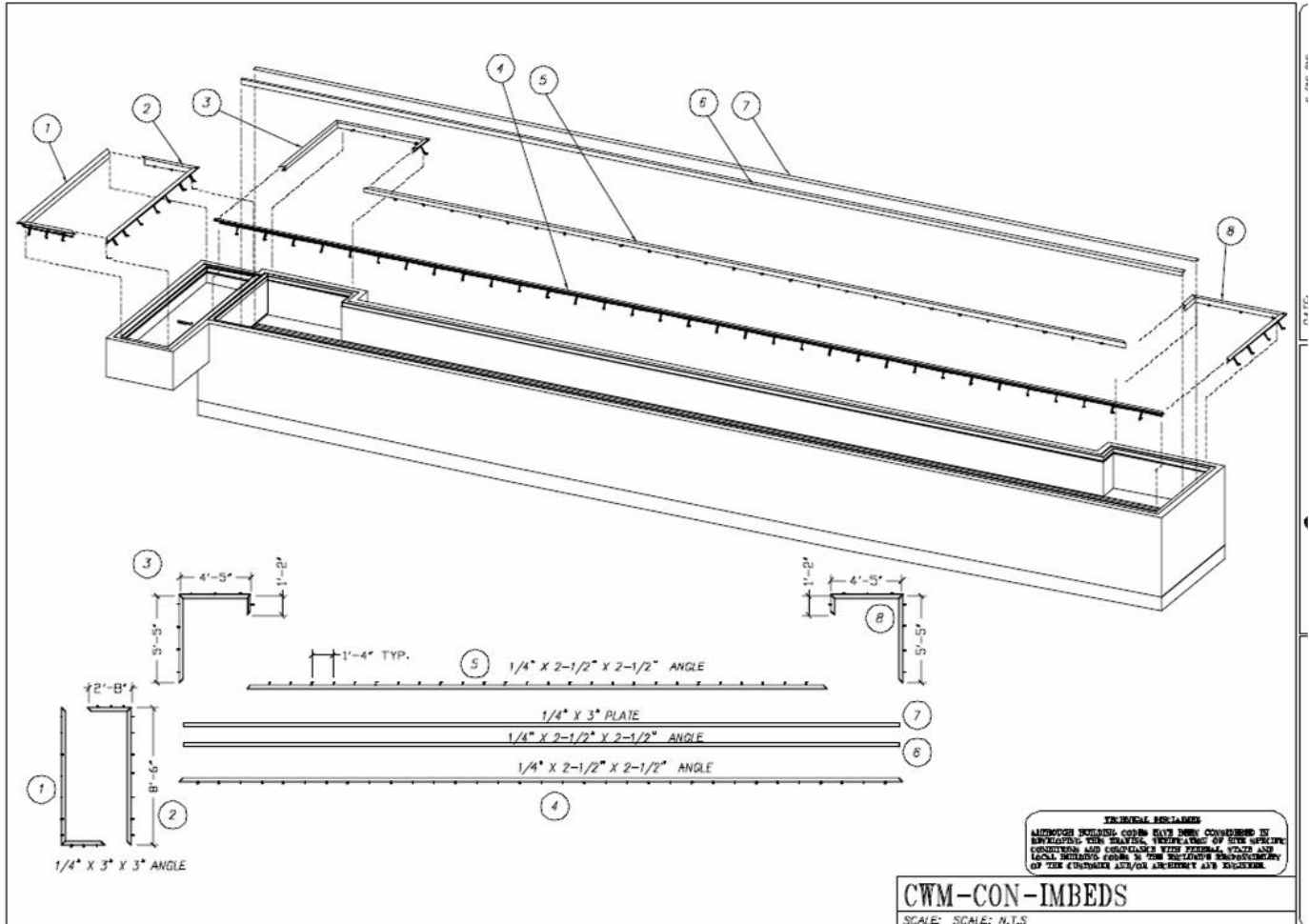

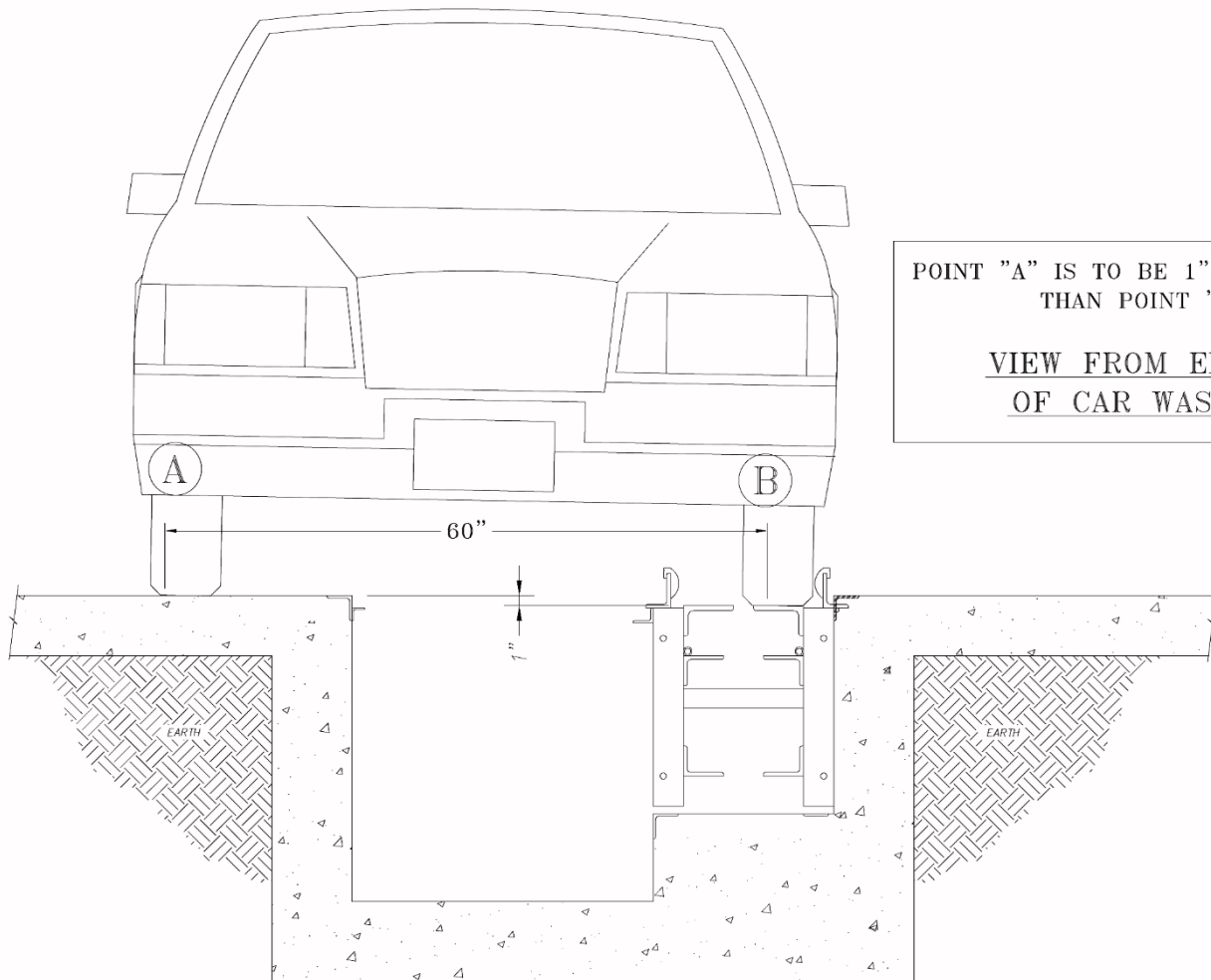

POINT "A" IS TO BE 1" HIGHER  
THAN POINT "B"

VIEW FROM EXIT  
OF CAR WASH

FRONT WHEEL PULL  
SECTION THRU TRENCH

**TECHNICAL DISCLAIMER**

ALTHOUGH BUILDING CODES HAVE BEEN CONSIDERED IN DEVELOPING THIS DRAWING, VERIFICATION OF SITE SPECIFIC CONDITIONS AND COMPLIANCE WITH FEDERAL, STATE AND LOCAL BUILDING CODES IS THE EXCLUSIVE RESPONSIBILITY OF THE CUSTOMER AND/OR ARCHITECT AND ENGINEER.

CWD-CONV-ELEVATION

SCALE: N.T.S

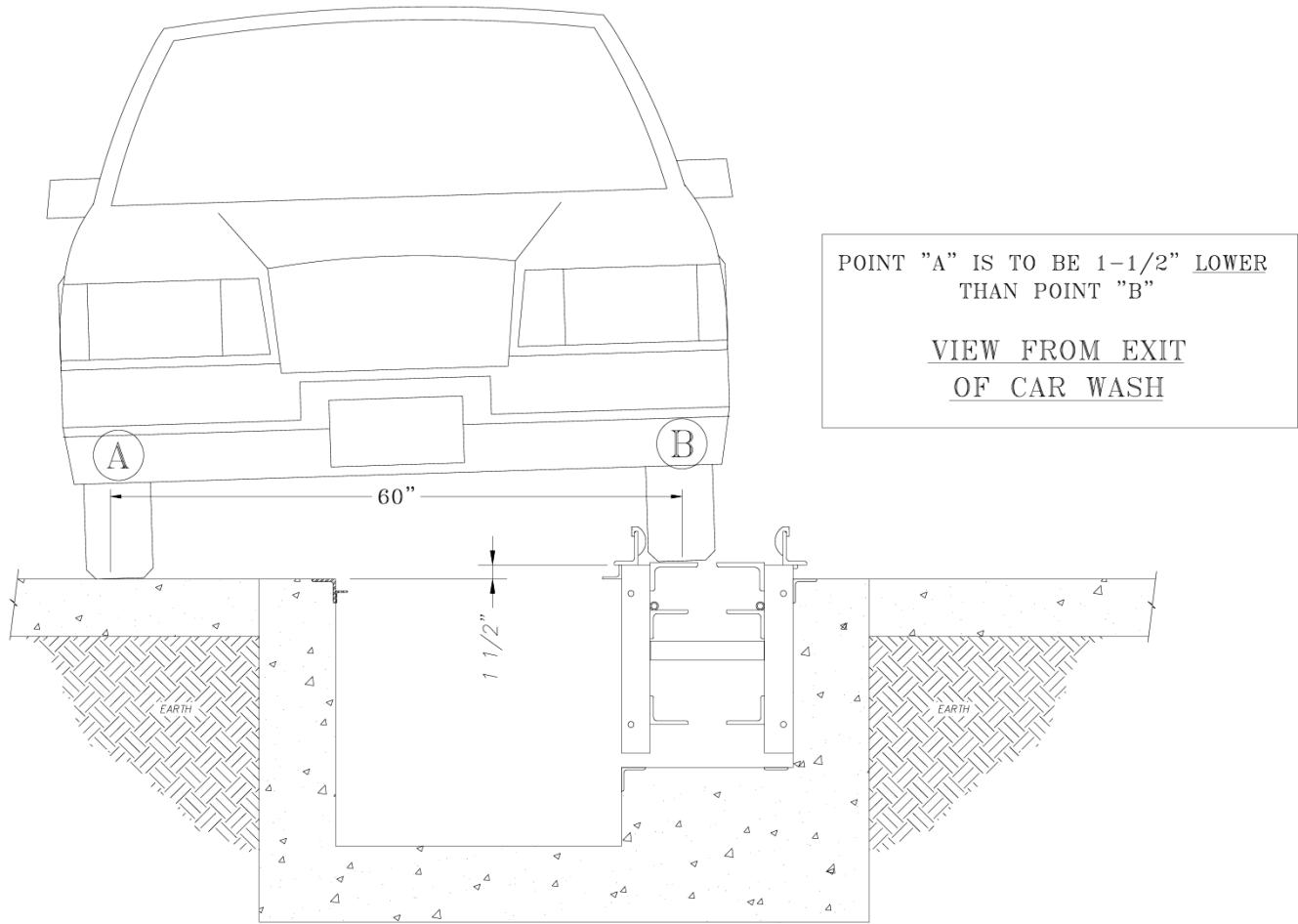

REAR WHEEL PUSH  
SECTION THRU TRENCH

**TECHNICAL DISCLAIMER**

ALTHOUGH BUILDING CODES HAVE BEEN CONSIDERED IN DEVELOPING THIS DRAWING, VERIFICATION OF SITE SPECIFIC CONDITIONS AND COMPLIANCE WITH FEDERAL, STATE AND LOCAL BUILDING CODES IS THE EXCLUSIVE RESPONSIBILITY OF THE CUSTOMER AND/OR ARCHITECT AND ENGINEER.

CWD-CONV-ELEVATION

SCALE: N.T.S

Gear box mounting plate should be installed with 2 ½" side **DOWN** as indicated by bull-nosed corner when uses on a 4-tooth sprocket.

Direction of Roller Travel

2 ½"

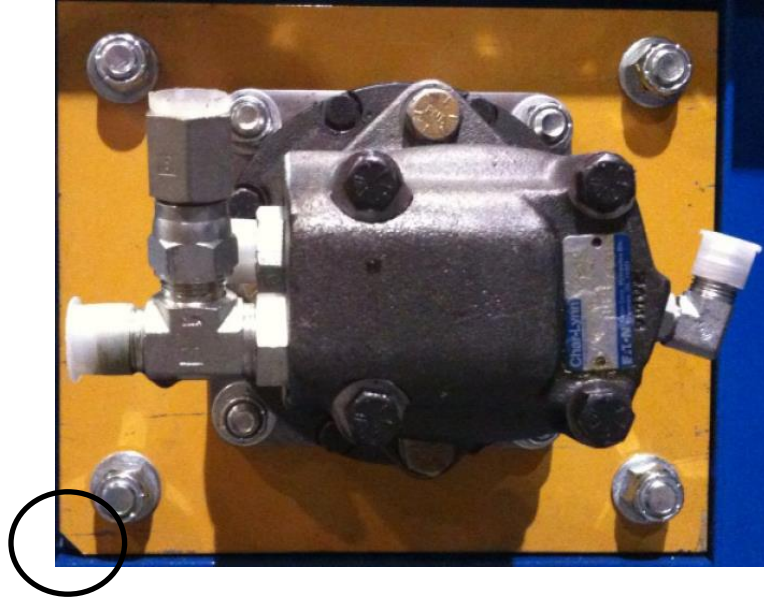

Gear box mounting plate should be installed with 2 ½" side **UP** as indicated by bull-nosed corner when used on a 12-tooth sprocket.



2 ½"

Direction of Roller Travel

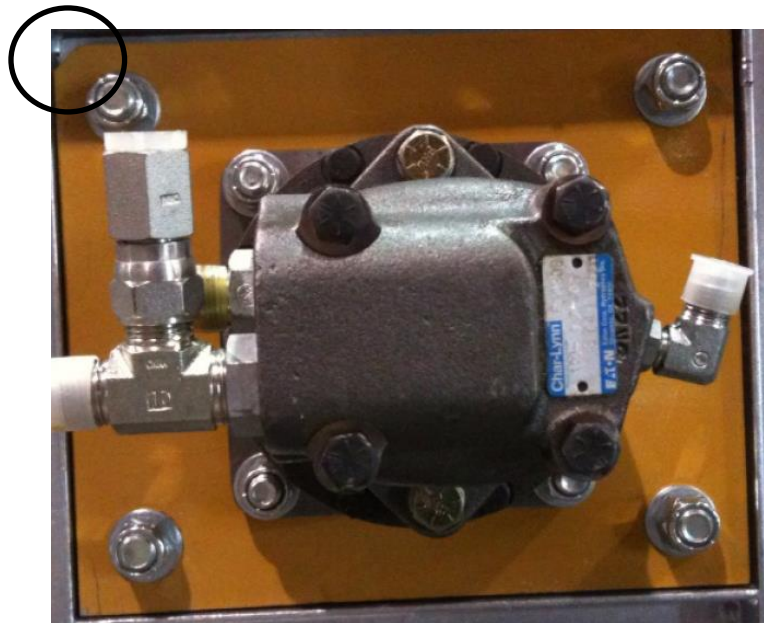



# Equipment Installation

**ACCURATE CONVEYOR INSTALLATION IS CRITICAL FOR PROPER OPERATION  
BE CERTAIN THAT YOUR INSTALLERS ARE WELL EXPERIENCED  
IN OVER AND UNDER CONVEYOR INSTALLATION**

## Conveyor Installation

### Tools

1. Safety Glasses
2. 1/2" Drive Ratchet Set
3. Standard Combo Wrenches
4. Sledgehammer
5. Tape Measure
6. Conveyor Leveling Tool
7. Conveyor Frame Lift
8. Cable Puller
9. 8" Bottle Jack
10. Various Size C Clamps
11. 5' Pry Bar
12. Welder
13. 6" Level
14. 4" Grinder
15. Sawzall
16. Forklift
17. Power Swaging Tool
18. Hose Cutter
19. Hose Cutter
20. Tape Measure

### Work Force

Three (3) persons

### Consumables

1. Anti-Seize Compound
2. Yellow Spray Paint
3. Marine Grease
4. Tie Wraps
5. 7/8" Clips
6. 3/4" Clamps

### Time (assuming no problems)

6.00 - 8.00 hours

## Installation Steps

### Self-Cleaning or Standard Conveyor

1. Prepare the pit for the beam placement if it is a self-cleaning pit. Prepare the shelf for conveyor installation if standard.
2. Start by cleaning the pit angle irons where the cross beams or conveyor are to be placed. Using a flat shovel, scrape the concrete from the angle iron and then sweep the area.
3. Make certain that there is no concrete left behind that could adversely affect the welds on the angle iron of the driver and passenger sides.
4. Lay the cross beams in the pit. One (1) beam needs to be placed at each leg with one at each seam. Start at the take-up section (entrance) and work toward the drive section (exit). Place the first beam even with the rear pit wall and place the second beam ten feet (10') from the pit wall. The next set of beams is placed fifteen feet (15') from where the first set of beams were placed if working with fifteen foot (15') sections. Make sure the beams are level by placing ¼" shims under the beams if necessary.

**Note:** If a standard conveyor shelf is used place the conveyor on the shelf.



5. Using a forklift, lifting strap, and long chain, lay the conveyor in place.
6. Locate the drive section and the take-up section, which may be bolted together.
7. Unbolt the two sections using a wrench and an impact gun. Then attach a lifting strap/chain to the take-up section, making certain it is attached at the center point for balance. The other end of the strap needs to be attached to the lift-jig.
8. Using the lifting strap, attach each section making sure it is balanced. Then place each section, individually, in the pit. Have one person in the pit to assist in the proper placement of the crossbeams.
9. Bring the take-up section into the tunnel and place it in the pit. Next, line up the take-up section with the rear of the pit wall, as the additional sections will be lined up based on the placement of the first piece.

10. With the forklift and attach the next section as noted in step 3, taking each section into the tunnel area until all sections are in place.



**Note:** When placing the conveyor on the crossbeams, some of the tubes may need to be placed on their ends. The conveyor measurement should start at zero on the entrance end for the first twenty five feet (25') then taper to one and a half inches (1.5"). The last fifteen to twenty five feet (15'-25') should taper to three quarters (3/4") of an inch.

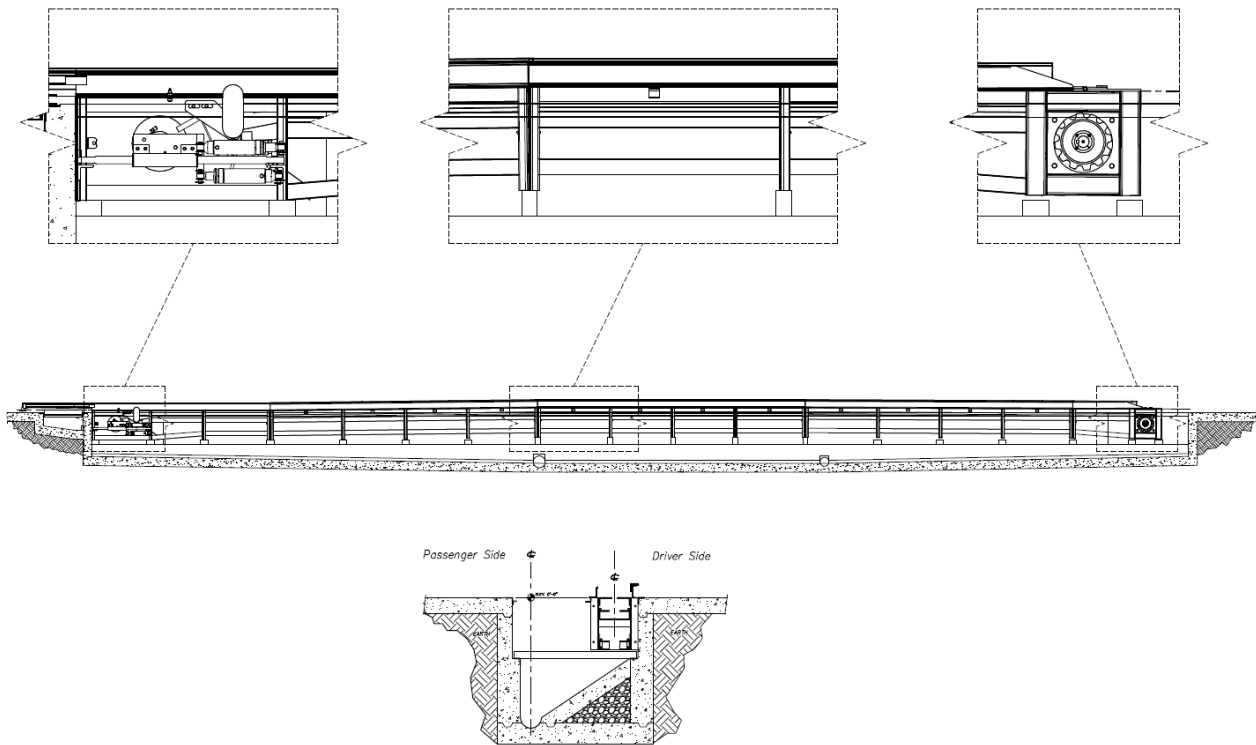





## Owner's Manual Over-Under Conveyor Soft-Drop

11. As each section is laid in the pit, make sure to butt it up against the previous section. All the sections will need to be re-adjusted before welding.
12. You will continue this process until all pieces of the conveyor have been laid in place.
13. The last piece of conveyor to be set in place is the drive section.

**Note:** When installing equipment that uses bolts it is necessary to apply Never Seize to the bolt to prevent the bolts from seizing. This procedure is applicable throughout this manual.

14. Using the leveling jig and starting at the take-up section place one side of the jig on the conveyor and the other side on the floor.
15. Then place the level on top of the jig and add the ¼" shim plates under the jig on the conveyor side until conveyor is level.



16. Using the jig, note the number of ¼" shim plates needed at each section of the conveyor (notations should be made at the back and front of each section) to ensure the conveyor is level.
17. Push the conveyor against the driver side pit wall.
18. Find the sideline that was placed at one hundred forty four inches (144") and using a tape measure, measure in towards the pit forty inches (40") and place a mark on the entrance pit wall. Repeat this process at the exit end.
19. Place a Tapcon® screw on the mark made on the pit wall at the entrance end. Repeat this process at the exit.
20. Using a masonry string, wrap one end of the string around the Tapcon® screw at the entrance end and tie it off.
21. Pull the string down to the exit, and keeping it taut, wrap it around the Tapcon® screw and tie it off.

22. Use this line down the center of the conveyor and move the conveyor until the line is centered the entire length of the conveyor. This will ensure your conveyor is straight for welding.
23. Gather the following tools to use in this process; welder, bottle jack, ¼" shim plates, protective clothing and a welding helmet.
24. Start welding the take-up section first. This is the most critical part for the conveyor welding, as the rest of the conveyor will be lined up off of this piece. Then line the take-up section flush with the wall in the rear of the pit, making sure it lined up perfectly and weld it to the cross beams. Then weld the cross beam to the angle iron in the pit shelf.



25. Next, weld the entrance guide rails onto the take-up section of the conveyor and then weld the guide rails on to the correlator.



26. Look at the shim plate markings made on the conveyor. Then, using the bottle jack, raise the section of conveyor up and adjust the cross beams if needed. Next, place the six inch (6") angle against the leg. Then weld the six inch (6") angle iron leg to the conveyor & cross beam. Next, weld the cross beam to the angle iron in the pit.



## Owner's Manual Over-Under Conveyor Soft-Drop

27. Continue this process until the drive section is reached. The drive section will have some space between the conveyor and the pit wall, and there will be a guide-off plate that needs to be welded in place to close that gap.
28. After all the welding of the conveyor is complete, cut the conveyor railing from the conveyor to allow for clearance of the Tire Brush and Tire Shiner. For the Tire Shiner, lower the section three inches (3") and then weld it in place. For the Tire Brush remove the section before welding.
29. Outside the entrance end of the tunnel assemble the chain sections 20' to 30' in length. Start each section with a roller, installing rollers at the proper spacing, and end each with no roller.
30. Remove the Take-Up cover plate.
31. Tie a rope around the first roller of a section of chain and rollers and pull it into the conveyor making sure the rollers except the first go into the middle deck of the conveyor.
32. When the section is almost into the conveyor attach the next section of chain and roller to the end. At some point the assembly will become too heavy to pull by hand, then the cable puller will need to be used.
33. When almost at the exit end of the tunnel remove the cover plate from the Drive section.
34. When the first roller reaches the Drive section of the conveyor pull it about six feet beyond the end of the conveyor.
35. Remove the rope or cable puller from the roller.
36. Insert the first roller around the Drive sprocket and into the bottom deck of the conveyor.
37. Remove the motor from the gearbox and pull the sun gear out.
38. Using the cable puller, continue to pull chain and roller sections into the conveyor by pulling the assembly back towards the entrance end of the tunnel.
39. When the last section of chain is attached and pulled into the conveyor, stop pulling it in when the end of that section is even with the end of the tunnel attach the Pin and Cotter section to the last section.
40. Feed the end of the Pin and Cotter section of chain around the Take-Up sprocket and pull it as close as possible to the first roller.
41. Attach the cable puller to the Take-Up Slide and the frame of the conveyor. Compress the tensions spring and tighten the nut down against the crossbeam.
42. Connect the first roller to the Pin and Cotter section of chain.
43. Loosen the nut from the crossbeam and run it back down to the cotter pin end.
44. Loosen and remove the cable puller from the Take-Up Slide.



# Owner's Manual

## Over-Under Conveyor Soft-Drop

45. Check the position of the Spring Tension Bolt. It should extend 2-3 inches beyond the crossbeam. If it does not remove or add links from the painted section of chain until it does. The air take-up should sit between the split collars.
46. Replace the cover plates at both ends of the conveyor.
47. Replace the Sun Gear in the Heco Gear Box.

### Hydraulic

48. Remove the plug from the port of the Conveyor hydraulic motor closest to the driver's side. Thread in a 1/2" x 5/8" o-ring fitting and tighten. This is the oil Feed port.
49. Remove the other plug and thread in a 1/2" JIC x 5/8" o-ring tee fitting and tighten with the tee portion facing down. This is the oil return port.
50. On the exit end of the motor remove the 1/4" o ring plug and replace it with a 3/8" JIC x 1/4" o-ring fitting. Tight the fitting so the JIC portion faces down. This is the return from the gearbox.
51. Coat the 3/8" MPT portion of the gearbox return hose with PTFE tape or paste. Thread it into the 1/2" JIC x 3/8" FPT adapter and tighten.
52. Thread the other end of the gear box return hose onto the 3/8" JIC Fitting in the return from the gearbox.
53. Set up the Power Swaging Tool in the tunnel and get out a reel of 1/2" Hydraulic hose in both Black and Orange. Crimp a 1/2 Female Swivel on the end of the black hose.
54. Screw a plug into the fitting to prevent any debris from entering the hose.
55. Snake the fitting end of the hose into the last chase way. Once the hose is thru the chase way, remove the plug and tighten the fitting to the Quick Disconnect fitting in the output port of the Top Power Pack.
56. Cut the hose to fit on the oil feed port with 12" to 18" of slack.
57. Repeat steps 6 thru 9 with the orange or red hose and attach it from the oil return port on the motor to the oil filter on the power pack

### Pneumatic

58. Get out a reel of 3/8" compressed air line (100PSI @ 0.5CFM) and place in the tunnel near the Take-Up end of the conveyor. Place an end cap over the line end to prevent any debris from entering line.
59. Snake the end of the line into the chase way to the Air Manifold with the valve for the Roller-Up function.



## Owner's Manual Over-Under Conveyor Soft-Drop

60. Once the hose is through the chase way, remove the cap and connect the line to the output of the air regulator/valve combination for the Roller-Up function. Leave enough slack in the line in case it must be connected to the other output.
61. Return to the Take-Up section of the conveyor and cut the line the proper length to connect to the Roller-Up air cylinder.
62. A manual drain valve should also be installed at the lowest point in the air line to facilitate draining liquid trapped in the line.
63. Repeat Steps 11 thru 15 for the other end of the Roller-Up air cylinder.

### Electrical

64. If the pulse switch is installed on the Drive end of the conveyor place a reel of 3-#16AWG wire cable in the tunnel near the Drive end of the conveyor and snake the end into the chase way to the tunnel controller.
65. If a remote pulse switch is being utilized run the 3-#16AWG wire cables from it to the tunnel controller.
66. Select one color wire (prefer white) and connect it to the common(C or COM) terminal on the pulse switch and to the common(C, COM or HOT) terminal on the tunnel controller.
67. Select another color wire (prefer black) and connect it to the switched (NO) terminal of the pulse switch and to the pulse signal input (Pulse or Clock) terminal on the tunnel controller.
68. Select the last color wire (prefer green) and connect it to the ground terminal of the pulse switch or metal casing, if no ground terminal is provided. Connect the other end to the earth ground (GRD) terminal on the tunnel controller.
69. Connect the wires to the Roller-Up air solenoid valve and to the Roller-Up function terminals on the tunnel equipment controller.
70. Connect the wires to the anti-jam switch and to the Anti-Jam function terminals on the tunnel equipment controller.



## Adjustments and Testing

### Conveyor Speed

1. Conveyor speed can be adjusted at the flow control valve on the Hydraulic Power Pack that supplies fluid for the Conveyor.
2. Conveyor speed may be set from 50 to 200 cars per hour depending on the equipment in the tunnel and the quality of wash desired.
3. To determine the speed of the chain measure the length in inches a roller travels in 15 seconds. That number will be the same as the number of cars per hour the conveyor is set to.

Inches of Roller Travel in 15 seconds = Cars Per Hour

### Speed and Torque Adjustment

1. Hydraulic
  - a. The speed can be adjusted on the flow control for the power pack.
  - b. To increase the speed move the handle on the flow control closer to the number 10.
  - c. To decrease the speed move the handle on the flow control closer to the number 1.
  - d. The torque must be set prior to operation and should be set between 600 and 900 PSI. For information on how to set the torque please refer to the Hydraulic Power Pack Manual.
2. Electric
  - a. The speed can be adjusted on the Variable Frequency Drive (VFD).
  - b. To increase the speed adjust the Hertz on the VFD to a higher number.
  - c. To decrease the speed adjust the Hertz on the VFD to a lower number.
  - d. The Overload on the Motor Starter protector(s) must be set at the lowest level to allow for operation. Adjust the amps in accordance with motor(s) name plate.

### Conveyor Stall Torque

1. Conveyor stall torque can be adjusted at the bypass valve on the Hydraulic Power Pack that supplies fluid for the Conveyor.
2. Pressure gauge should indicate 1200PSI when the Power Pack is running with the conveyor stalled.



# Owner's Manual Over-Under Conveyor Soft-Drop

## Roller-Up Function (Spring)

1. Adjustment is made at air regulator on the air distribution manifold.
2. Should be set to 70 - 80PSI for up position and 30 – 60PSI for down position.
3. Observe movement of Roller-Up forks should smoothly and completely up and down

## Roller-Up Function (Air)

1. Adjustment is made at air regulator on the Control Panel.
2. Should be set to 40-50PSI at the switch.
3. Observe movement of Roller-Up forks should smoothly and completely up and down

## Tension

1. The air take-up should have 40 to 50PSI at the switch.



## Chain Tension Adjustment - Spring

1. This is the most common service performed on the Conveyor.
2. Run conveyor to position chain so removable links are easy to work on and stop it there.
3. Check the tension bolt in the Take-Up section of the conveyor if there is less 1" of threads between the nut and the cross plate continue.
4. Run the Conveyor until you see the master link section approaching the Take-Up section and stop the Conveyor just before that section reaches the Take-Up Sprocket.

**Caution:** You must shut off all power to the conveyor and lock out the Motor Control Center before getting in conveyor pit and starting this repair.

5. Shut off all power to the conveyor and lock out the Motor Control Center.
6. Use cable puller to pull chain together to create slack so a chain link can be disconnected.
7. Screw nut down tension bolt so nut is flush with cross beam, this will hold slack in chain if hand wrench fails.
8. Remove pin and cotter from a chain link.
9. Remove pin and cotter from other end of the same chain link and remove the link.
10. Reconnect the ends of the chain using pin and cotter, replace cotter if damaged.
11. Screw nut back up tension bolt to the cotter installed in its end.
12. Carefully release cable puller to allow chain to be tensioned.

**Caution:** Before returning power to the conveyor and removing lock out from the Motor Control Center make sure all personnel are clear of the operational area.

13. Remove lock-out and run conveyor, check tension bolt to ensure there is more than 1" of thread show between nut and cross beam. If not repeat Steps 1 – 10.



## Chain Tension Adjustment - Air

1. This is the most common service performed on the Conveyor.
2. Run conveyor to position chain so removable links are easy to work on and stop it there.
3. Check the position of the carriage on the slide tube if there is less than ½" between the carriage and split collar a link should be removed. ( See figure #1 for collar placement)
4. Run the Conveyor until you see the master link section approaching the Take-Up section and stop the Conveyor just before that section reaches the Take-Up Sprocket.

**Caution:** You must shut off all power to the conveyor and lock out the Motor Control Center before getting in conveyor pit and starting this repair.

5. Shut off all power to the conveyor and lock out the Motor Control Center.
6. Release the air pressure to the shocks using the tension valve on the control panel.

**Note:** It may be necessary to use a pry bar to move the carriage all the way forward.

7. Remove pin and cotter from a chain link.
8. Remove pin and cotter from other end of the same chain link and remove the link.
9. Reconnect the ends of the chain using pin and cotter, replace cotter if damaged.
10. Flip the tension valve back to the on position to allow chain to be tensioned.

**Note:** If chain tension appears not to be working properly, check the air cylinders for water. If water is encountered, cylinders will need to be replaced and an air dryer added to the air compressor.

**Caution:** Before returning power to the conveyor and removing lock out from the Motor Control Center make sure all personnel are clear of the operational area.

1. Remove lock-out and run conveyor, make sure the carriage sits between the two collars. If not repeat Steps 1 – 9.

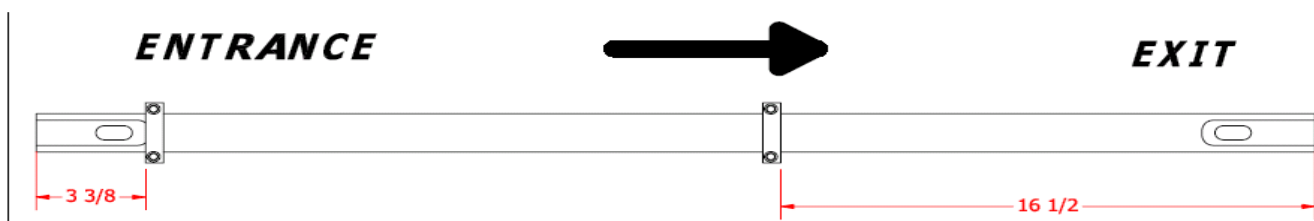

**Figure #1**



## \*GENERAL OPERATION\*

### CONVEYOR OPERATION

Starting and stopping conveyor movement is controlled by push-button switches that operate the motor starter coil for the conveyor drive hydraulic power pack.

The "Roller Up" function, to move vehicles through the car wash on the conveyor is controlled for each vehicle by a push-button switch on the tunnel controller push-button station. "Back Up" rollers may be raised automatically through the tunnel controller.

The "Anti-Jam" function prevents roller jams caused by the rollers being brought up at a point that would cause them to jam in the transition to the top deck.

The speed of conveyor movement may be changed by the flow control valve on the conveyor hydraulic power pack. See Adjustments and Testing Section.

### OPTIONAL EQUIPMENT OPERATION

**PULSE SWITCH KIT** - Each time any magnet on the circular aluminum disc passes within range of the solid state sensor switch an electrical pulse signal is sent to the equipment Programmer to start and stop each piece of equipment according to the cumulative pulse count for each vehicle. The quantity of pulses transmitted in any given time frame is directly proportional to the speed of the conveyor.

**SAFETY HORN WARNING KIT** - Each time the conveyor start switch is pressed the horn will sound for a pre-determined period of time BEFORE the conveyor begins to move. Five seconds minimum of horn operation is suggested.

**ANTI-COLLISION CONTROL KIT** - When a vehicle has departed the last piece of equipment in the wash tunnel but has not vacated the exit concrete pad of the wash tunnel the Anti-Collision sensor detects this vehicle's presence. When a second vehicle approaches the last piece of equipment in the wash tunnel the Anti-Collision control sensor that has detected the first vehicle on the exit pad causes the conveyor to stop thereby preventing the second vehicle from hitting the first vehicle. The conveyor will not start automatically after the first vehicle clears the anti-collision sensor. As a safety measure conveyor restart can only occur from a manual start operation.



## \*PREVENTIVE MAINTENANCE\*

### DAILY

1. Opening Checks
  - a. Check for leaks around hoses and fittings, repair any hydraulic leaks immediately.
    - 1) At Drive Section, check for hydraulic leaks around the Drive Motor and connectors.
    - 2) At Take-Up Section, check for air leaks around Roller-Up cylinder and shocks.
2. Operational Checks
  - a. Check the chain tension bolt, if less than 2 inches of threads showing plan to remove link from chain during weekly maintenance to ensure the chain does not become slack and cause chain jams.
  - b. General examination of general operation, listening for any unusual noises. Observe the operation of the conveyor, the roller-up function, and power pack, watch for anything out of place and listen for any unusual noises.
3. Closing Checks
  - a. Remove pit grading from the Take-Up and Drive sections of the conveyor and wash down the conveyor using prep gun. This should be done at the end of each day to prevent buildup which could cause chain jams and premature wear.
  - b. Open manual drain valves in the Roller-Up air cylinder air lines at the end of business each day.

### WEEKLY

1. Perform a close inspection of operation.
  - a. Check Roller-Up operation, fork alignment and freedom of travel at the Take-Up section.
  - b. Check for oil leaks around drive motor and speed reducer at the Drive section.
  - c. Check for sprocket alignment and sprocket wear at both Take-Up and Drive sections.
2. Wipe excess dirt and grime off the Take-Up slides with a clean rag.
3. Grease Take-Up shaft bearings with 1-2 pumps per bearing.
4. Check the chain tension bolt, if less than 1" remove a chain link.
5. Spray lubricant on the air cylinder rod end and clevis.



# Owner's Manual Over-Under Conveyor Soft-Drop

## MONTHLY

1. Closely inspect each roller, chain link and cotter pin closely for wear and damage, replace, as necessary.
2. Inspecting all hardware and fittings for tightness.
3. Grease the 2 slide tubes, until grease comes out the weep hole.
4. Clean the entire assembly thoroughly.

## ANNUALLY

1. Drain, flush, and refill the hydraulic power pack with new, non-foaming, non-detergent hydraulic fluid (ISO #46).
2. If the chain is starting to wear unevenly, flip the chain upside down to extend its life.

## **\*EXPLODED VIEWS\***

### **Take-Up Section Tension Spring**

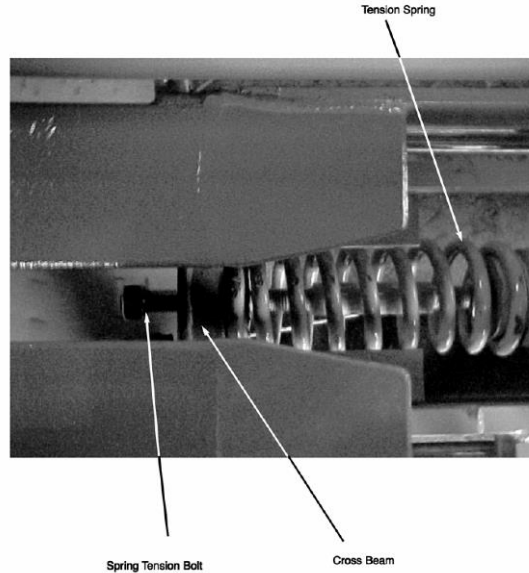

### **Preventive Maintenance on Take-Up Section**

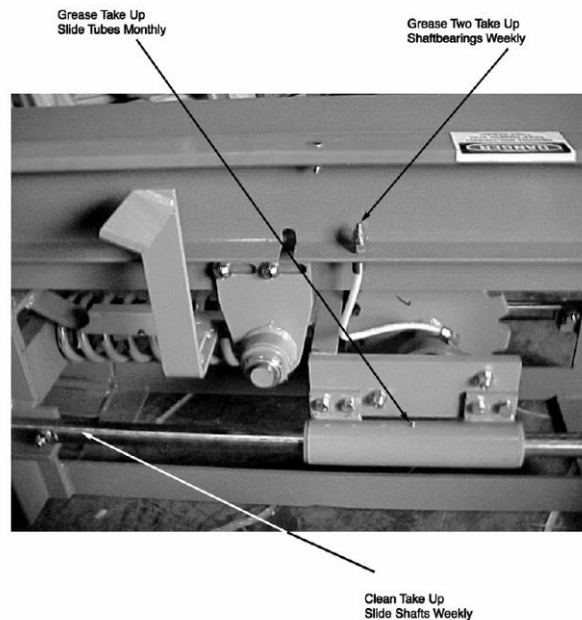

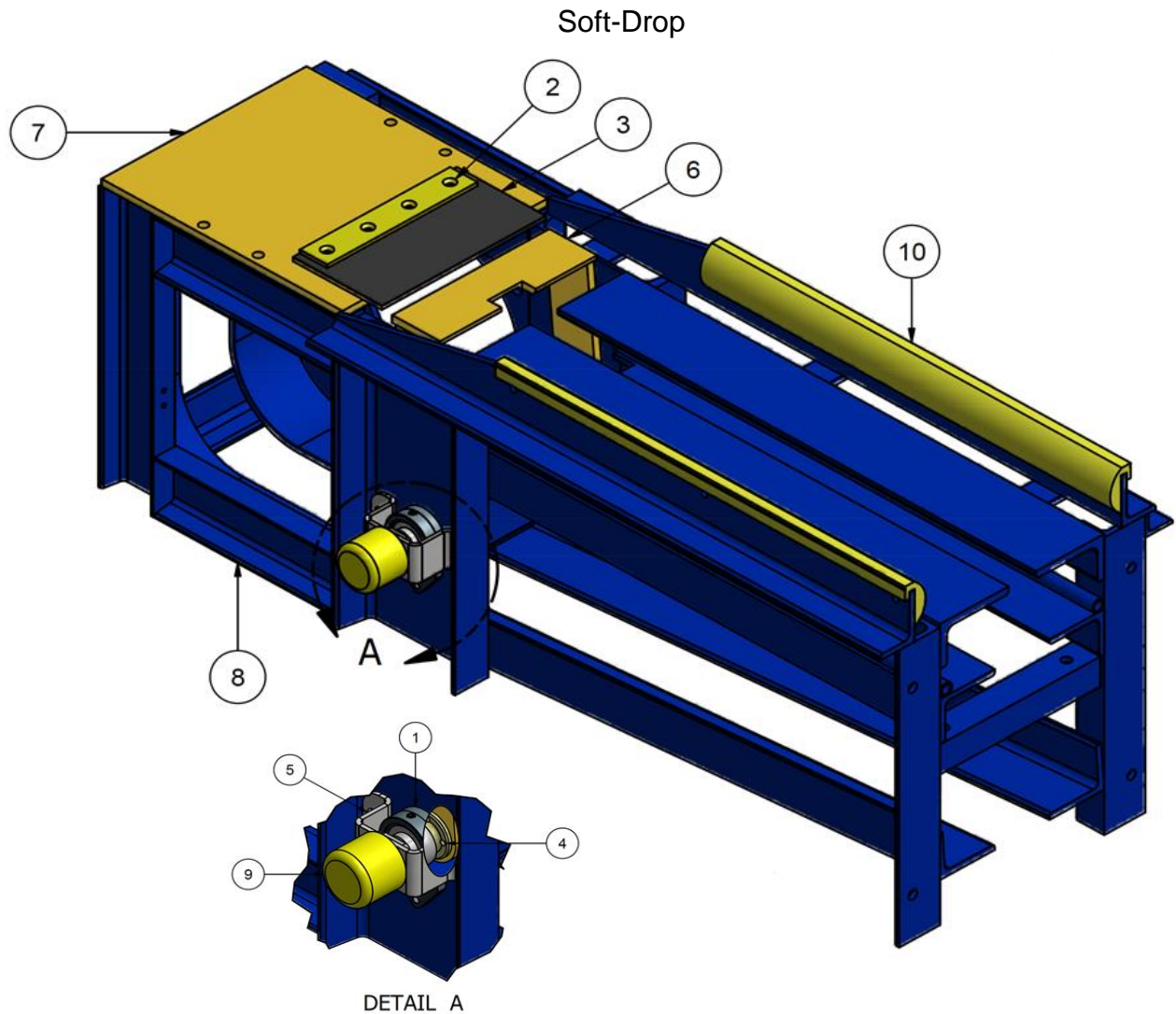

Item #	Description	Part Number
1	Bearing, 3-bolt flange 1.25in	10006254
2	Conveyor, mounting plate hinge painted	20004759
3	Conveyor, rubber hinge exit 12 x 6 1/2 inch	20004763
4	Spindle, Soft-Drop roller gate	20012332
5	Rosta unit, Soft-Drop Conveyor gate	20012333
6	Roller gate, Soft-Drop	20012337
7	Cover plate, 15 x 17 5/8, Soft-Drop SEC	20012338
8	Soft-Drop, Exit section painted weld	20012447
9	Soft-Drop, Bearing plastic cover	20012450
10	Banana Peel, Rail bar conveyors	10006495

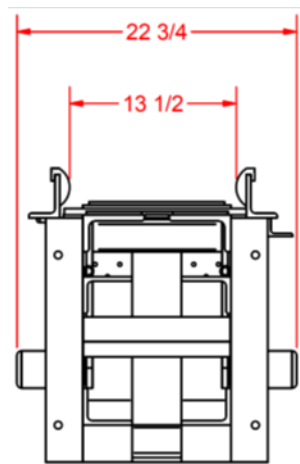
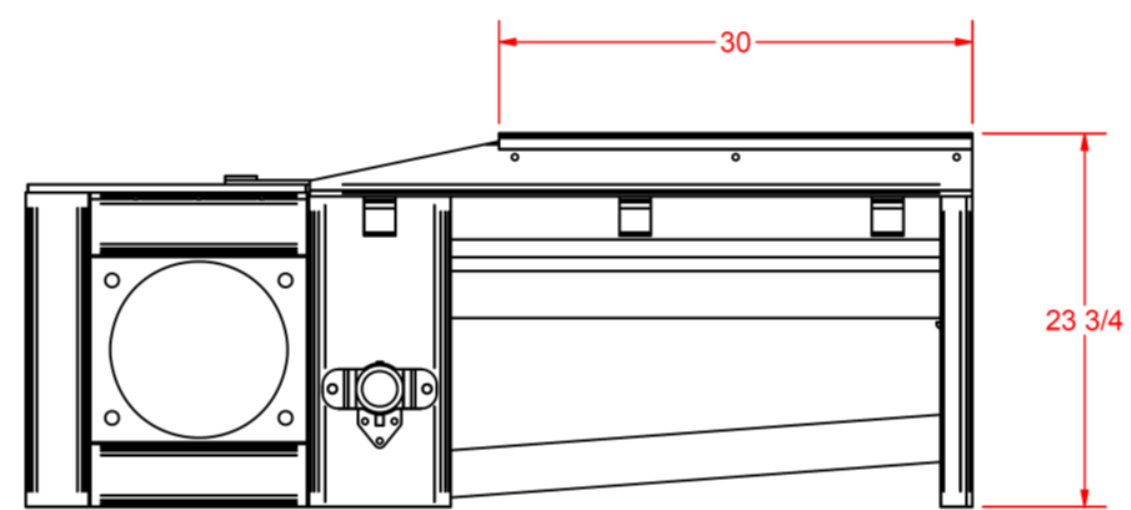
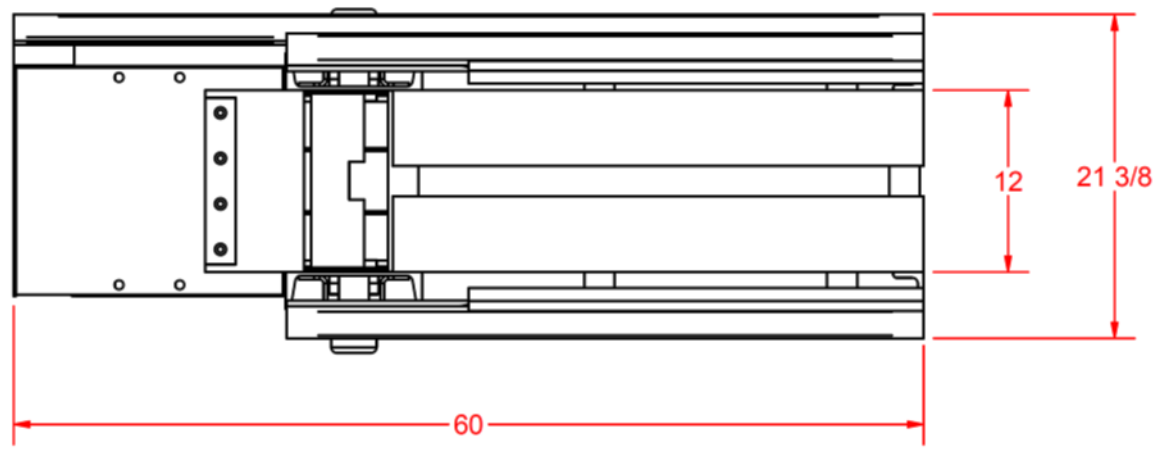

## Conveyor Hydraulic Drive Motor

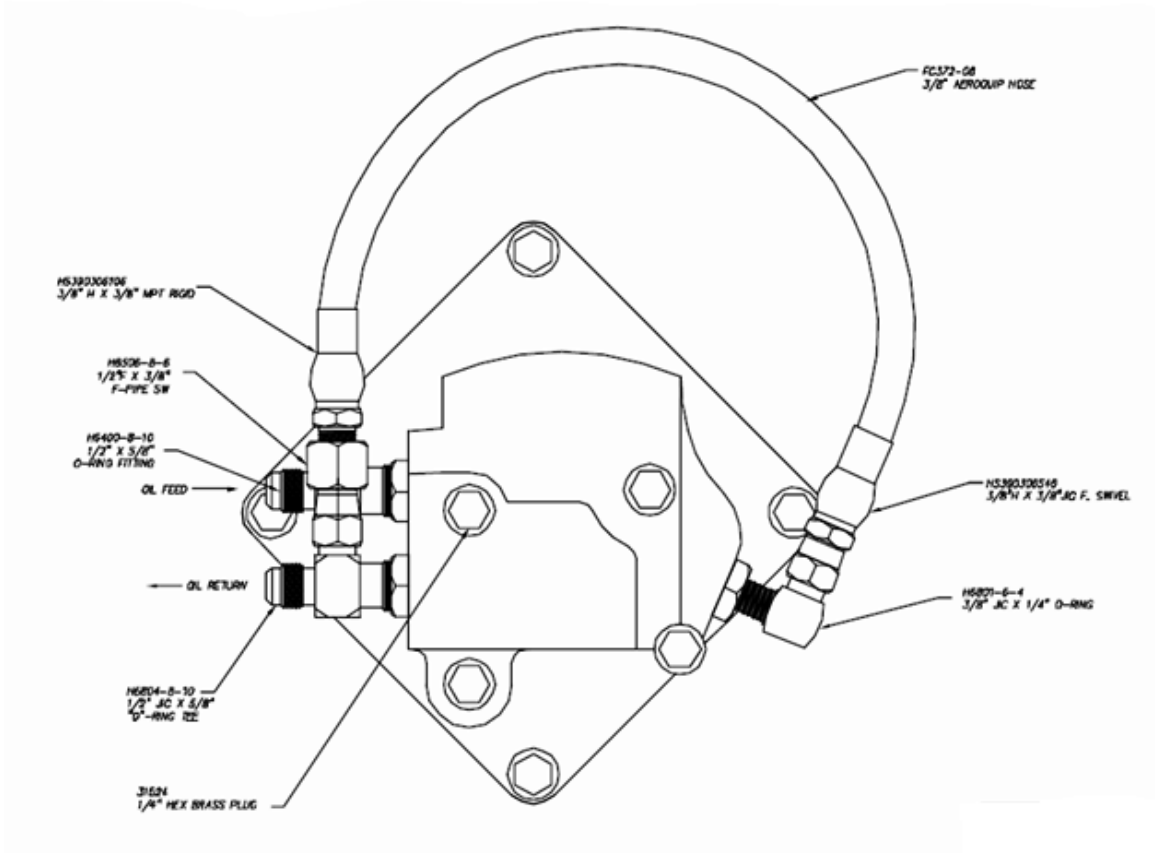

**CWD – HECO – 100 – HECO – 600**



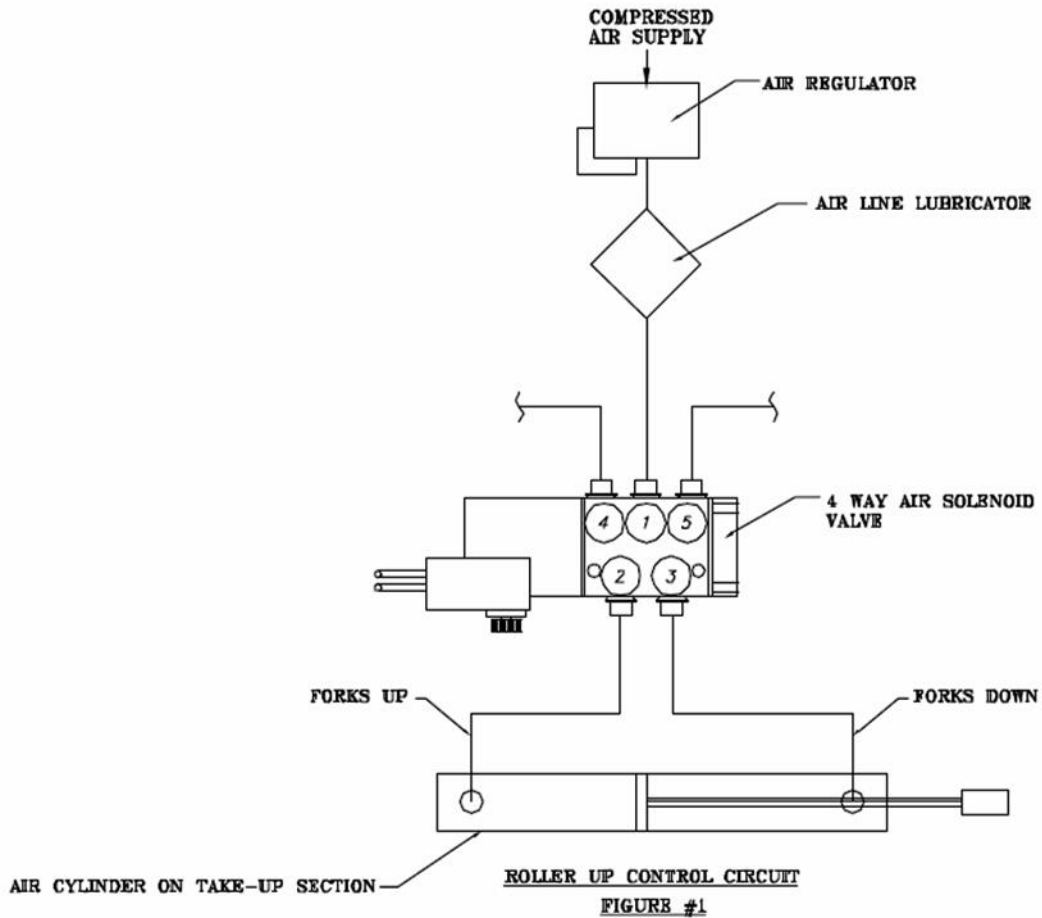

**CWC – ROLLER UP CONTROL CIR.**

Quick reference chart for calculating conveyor speed in theoretical Cars per Hour.

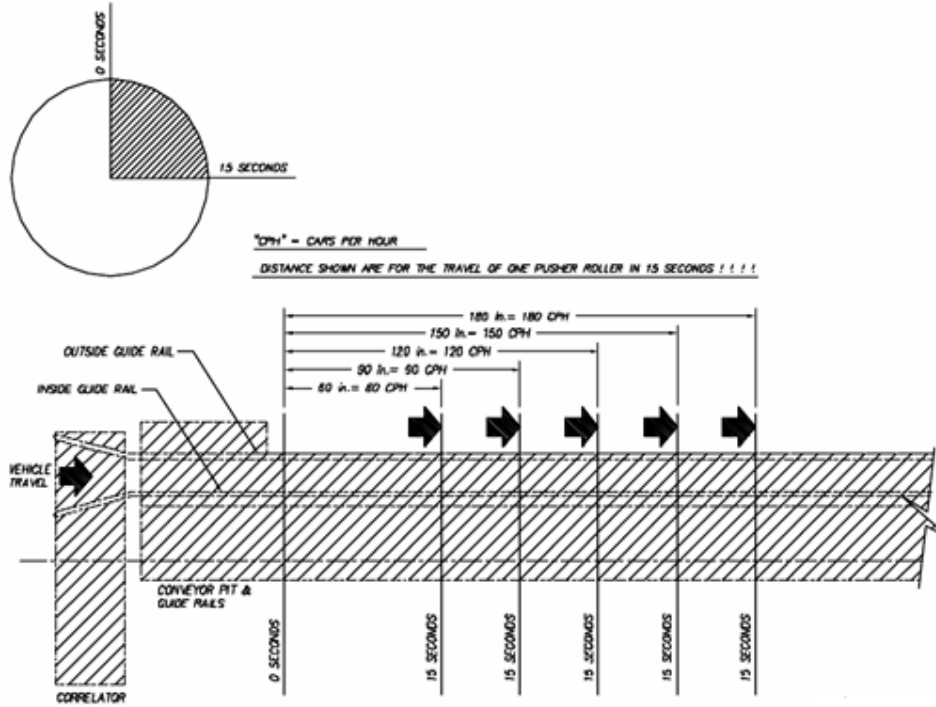

## \*PARTS LIST\*

### SONNY'S New Soft-Drop Conveyor Pricing\*

Pricing is for our most popular conveyor lengths with a Hydraulic Drive and includes chain and rollers @ 3' 6" or 3' 4" Roller Spacing.

SONNY'S True-Track™  
4:2 Wheel Roller



ROLLERS	Direct-Connect 4Wheel		Mid-Profile 6Wheel		Direct-Connect 4Wheel		True-Track™ 4:2 Wheel	
CHAIN	LOG CHAIN		SC78 CHAIN		X458 CHAIN		LOG CHAIN	
Conveyor Length	PAINTED	GALVANIZED	PAINTED	GALVANIZED	PAINTED	GALVANIZED	PAINTED	GALVANIZED
45'	\$22,711.78	\$25,485.78	\$20,330.98	\$22,806.98	\$20,392.00	\$22,868.00	\$23,364.11	\$26,138.11
60'	\$25,869.25	\$29,592.25	\$23,311.37	\$26,736.37	\$23,376.95	\$26,801.95	\$26,793.25	\$30,516.25
80'	\$30,327.96	\$35,277.96	\$27,768.76	\$32,420.76	\$27,840.58	\$32,492.58	\$31,551.06	\$36,501.06
100'	\$34,611.99	\$41,225.99	\$31,963.35	\$38,279.35	\$32,041.41	\$38,357.41	\$36,161.25	\$42,775.25
120'	\$38,420.09	\$45,939.09	\$35,682.13	\$42,903.13	\$35,854.43	\$43,075.43	\$40,268.33	\$47,787.33
140'	\$42,966.92	\$51,712.92	\$40,082.01	\$48,530.01	\$40,318.06	\$48,766.06	\$45,141.32	\$53,887.32
160'	\$47,065.63	\$57,475.63	\$44,236.91	\$54,348.91	\$44,421.69	\$54,533.69	\$50,039.01	\$60,449.01

### SONNY'S New Soft-Drop Conveyor Trap Door

Our clients asked us for a quieter exit end trap door that would last longer with less maintenance and provide a smoother, more customer friendly transition of the car off the conveyor. SONNY'S new Soft-Drop conveyor trap door utilizes a revolutionary new coupler to eliminate the door entirely! No counter weights, no springs, no stops, just a simple mechanical innovation that will deliver reliable performance car after car, year after year. Standard on all new conveyors, owners of existing conveyors can update to the latest technology by replacing only the 5-foot drive section frame work of their conveyor.

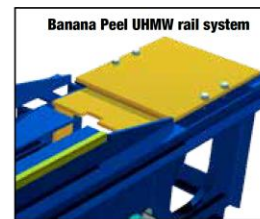

#### Choose Your Finish



**Painted Conveyor**  
Standard surface delivers excellent corrosion resistance at an affordable price.

OR



**Galvanized Conveyor**  
Optional surface coating can add years of life to your conveyor frame.

#### Choose Your Drive



**Hydraulic Drive**  
Simple, safe, and durable choice for wet environment applications.

OR



**Electric Drive**  
Reduce utility consumption and eliminate the potential for hydraulic leaks.

#### Choose Your Take-Up



**Spring Take-up**  
Long time industry standard for durability and reliability.

OR



**Air Take-up**  
Automatically adjusts to keep proper tension and easily releases for maintenance.

#### Choose Your Chain



**Log Chain**  
- Most durable  
- Remove links without tools  
- Easiest to maintain



**X-458**  
- Remove links without tools



**SC78**  
- Is the durable industry standard  
- Compatible with older style D88K Chain



**D88K**  
- Self-locking chain.  
(Available for 7" 4" spacing. Call for pricing)

#### Standard Features

- Anti-jam roller guides
  - Exposed grease fittings for easy application
  - Easy maintenance through access doors
  - Durable 1/2in thick top deck & 3/8in steel frame
  - Reliable chain guides included (#20005397)
  - Take-up idler sprocket or drum
  - Roller-down door is 3/8in steel with heavy-duty rubber hinge
  - Exclusive double roller take-up bearings
  - 1 1/2in stainless steel take-up adjustment shaft with UHMW poly bushings
  - Heco direct-drive gear box available with electric or hydraulic motor
- \* Grating and Kick-Off Plates are sold separately. Pricing as of 02 / 2014

#### Convert Your Existing conveyor.

Description	Price
Painted Heco Box Conversion	\$1,999.00
Galvanized Heco Box Conversion	2,249.00



### Take-Up Bearing

- Heavy duty, double roller bearing
- Special 2-bolt design fits all SONNY'S conveyors

Item #	Description	"E"	Price
10007637	Bearing, 2Bolt Flange 1 15/16in Timken	6 3/16in	\$180.27
10004874	Conveyor Bearing Grease Kit (2 needed)	-	26.99
10004171	50C250HCSSZ Hex Bolt 1/2-13 x 2 1/2 Zc	-	0.59
10001891	50NWUS0Z Washer 1/2in Flat USS Zc	-	0.06
10002825	50CNNE0Z Hex Nut Nylon 1/2-13 Zc	-	0.12



### 4-Way Pneumatic Valve

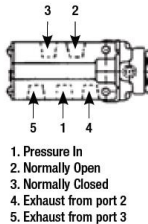

- Unique patented MACSOLENOID® valves for fastest possible response time
- 1-pc bonded seal spool for extended life
- Valves can be piped as 4-way, normally-closed or normally-open
- All Ports 1/4in, Conduit 1/2in

Item #	Description	Price
10006350	Mac, Val 811CPM-224CA152 4Way C24VAC	\$61.48
10006351	Mac, Val 811CPM-114CA152 4Way C120VAC	61.48

### Chain Guide



Install the first chain guide 15ft from entrance trap door and every 15ft thereafter for the length of your conveyor.

Item #	Description	Price
20005397*	Chain Guide, Heavy Duty w/Hardware	\$71.75
20003753	Chain Guide, UHMW Blocks w/Hardware	20.60

\* Includes mounting hardware

### Weldment Replacement for Roller-Up Guide Bars

- 13 3/4in x 1in Diameter
- 30° cut end



Item #	Description	Price
20002030	Conveyor, Roller Up Guides Pair	\$30.90

### Weldment Replacement for Door Rest

Top shelf



Item #	Description	Price
20002106	Conveyor, Angle Door (Pair) 3 x 5 x 1	\$103.00

### Weldment Replacement for Guide Angle

- Middle shelf
- Replaces Z plates



Item #	Description	Price
20002449	Conveyor, Angle Guide (Pair)	\$103.00

### Weldment Replacement for Conveyor Fork Z Ramp Guide (Before 2007)

Old style middle shelf



Item #	Description	Price
20003728	Conveyor, Z Plate Pair Weldment	\$25.70



Char-Lynn®

### Char-Lynn® 2000 Series – Use With Heco Gear Boxes



20003118



\*10004119

Item #	Description	Price
20003118	Char-Lynn 2000 106-1012-006 11.9 Cu In	\$371.79
10004911	Char-Lynn 61259 Seal Kit for 106 Series	23.99
10004119*	Heco, Bolt Kit for 16E Series	13.97

\*If buying Char-Lynn motor only, it's recommended to also order the 10004119 bolt & O-ring kit.

Heco GEAR

### Heco Gear Box

Includes Bolt Kit & O-Ring #10004119



10009010



10007276



10007099

Item #	Description	Price
10009010	Heco, Center Flange HC16CF 16E Series	\$977.34
10006837	Heco, Seal Kit Nickel Plated 16E Series	87.75
10007276	Heco, Sungear Adapter for 16E Series	124.80
10007099	50R250RKS0 Key Stock 1/2 x 2 1/2 Stl	2.80

### Heco Hose Kit

Replacement hose and fitting kit that runs from the Char-Lynn cap drain to the hydraulic return line.



20002097

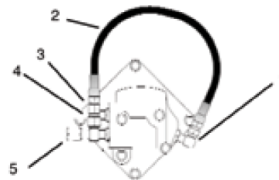

#### Included in kit

1. H6801-6-4 3/8in MJIC X 1/4 "O" Ring
2. FC06FJSMP 25in 3/8 Hose w 3/8 FJIC SW X 3/8 MPT
3. H6506-8-6 Swivel adapter 1/2 FJIC X 3/8 FNTP
4. 10000961 1/2 MJIC X 5/8 M "O" Ring Fitting
5. H6804-8-10 1/2 MJIC X 5/8 "O" Ring Tee

Item #	Description	Price
20002097	Heco, Hose Kit	\$52.50

### Entrance Carriage Slide Tube for all SONNY'S Over-Under Conveyors

SONNY'S



20004326

20002341

20004761

10003420

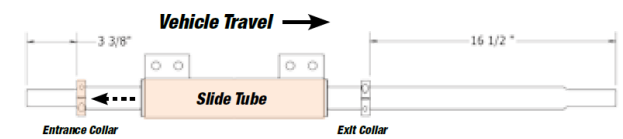

When take-up slide tube reaches the entrance collar, chain links need to be removed to maintain proper tension.

Item #	Description	Qty Needed	Price
20004326	Bushing, Slide Tube 2 1/2 OD x 1.531 ID	4	\$4.59
20002341	Tube, Slide Take Up w/ Bushings	2	80.45
20004761	Guide Bar, Take-Up Dolley 1 1/2in SS Rnd	2	215.30
10003420	Collar, 2pc Clamp 1 1/2in Zinc Plated	4	9.89

### Exit Rubber Belt

Reduces noise from rollers returning to bottom deck.



20001467

10002907

10003238

Item #	Description	Qty Needed	Price
20001467	Rubber, Roller Belt Exit w/ Holes	2	\$16.40
10002907	25C75HCS5Z Hex Bolt 1/4-20 x 3/4 Zc	8	0.07
10003238	25C43NTTOZ Tee Nut Stl Zc 1/4-20 x 7/16	8	0.09

### Heco Exit Drive Plate for all SONNY'S Over-Under Conveyors

SONNY'S

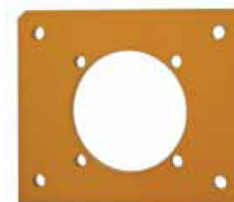

20004762

Item #	Description	Price
20004762	Heco Plate, Spring and Air Take Up	\$61.30
10003183	Conveyor Heco, Plate Bolt Kit-8 total	9.66

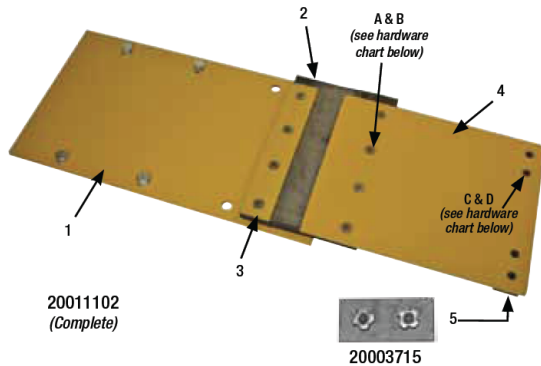

## Entrance Trap Door

- Rubber hinge
- Can retrofit to any existing SONNY'S conveyor

#	Item #	Description	Price
-	20011102	Conveyor, Entrance Door Kit	<b>\$283.50</b>
1	20003724	Conveyor, Plate 22in x 12in x 3/8in	<b>80.12</b>
2	20001574	Conveyor, Rubber Hinge Entrance	<b>31.40</b>
3	20004759	Conveyor, Mounting Plate Hinge Painted	<b>20.58</b>
4	20002155	Conveyor, Entrance Door Plate	<b>72.45</b>
5	20003715	Conveyor, Ent Rubber Stop Pair w/Screws	<b>9.20</b>

20011102  
(Complete)

20003715

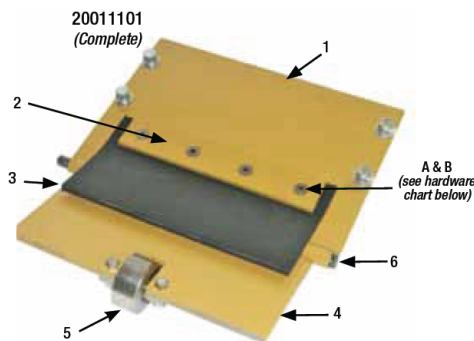

## Exit Trap Door

- Rubber Hinge
- Great for all operations
- Short Door
- Can retrofit to any existing SONNY'S conveyor

#	Item #	Description	Price
-	20011101	Conveyor, Exit Door Complete w/Flap Kit	<b>\$325.50</b>
1	20002132	Conveyor, Exit Door Plate 15in x 11in	<b>71.40</b>
2	20004759	Conveyor, Mounting Plate Hinge Painted	<b>20.58</b>
3	20004763	Conveyor, Rubber Hinge Exit 12 x 6 1/2in	<b>31.40</b>
4	20001889	Conveyor, Exit Door 6in x 13in x 3/8in	<b>84.37</b>
5	20004839	Conveyor, Trap Door Roller & Shaft SS	<b>32.89</b>
6	20003735	Conveyor, Exit Door Pin 15.5in x 9/16Dia	<b>10.45</b>

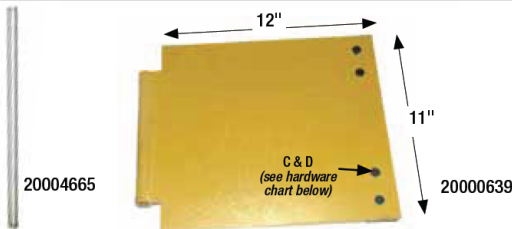

## Old Style Entrance Trap Door

Item #	Description	Price
20004665	Conveyor, Ent Door Pin 12in x 9/16Dia	<b>\$10.45</b>
20000639	Conveyor, Old Style Ent Door 12in x 11in	<b>54.08</b>



## Old Style Exit Trap Door, Roller & Shaft

Item #	Description	Price
20003748	Conveyor, Exit Cover Plate 11in x 15in	<b>\$54.08</b>
20004434	Conveyor, Exit Door 10in x 9.5in w/Pads	<b>54.61</b>
20003715	Conveyor, Ent Rubber Stop Pair w/Screws	<b>9.20</b>
20011111	Conveyor, Ex Dr Pin 15.5in x 9/16Dia Kit	<b>6.67</b>
20004839	Conveyor, Trap Door Roller & Shaft SS	<b>32.89</b>

## Hardware for all Trap Doors

10005956



Item #	Description	20011102	20011101	20000639	20004434	Price
A 10005956	37C125KFCS Soc Cap Screw 3/8-16 x 1 1/4	Qty. 8	Qty. 4	-	-	<b>\$0.65</b>
B 10004501	37CNNTS Thin Nylon-Insert Locknut 3/8-16	Qty. 8	Qty. 4	-	-	<b>0.24</b>
C 10003073	25C62KFCD 1/4-20 x 5/8 Socket Cap	Qty. 4	-	Qty. 4	Qty. 4	<b>0.08</b>
D 10003238	25C43NTT0Z Tee Nut Stil Zc 1/4-20 x 7/16	Qty. 4	-	Qty. 4	Qty. 4	<b>0.09</b>



### D88K Chain & Carrier Link



Pricing based on minimum 100 feet of chain.

TRAVEL →

Item #	Description	Price
10006798	Chain, D88K Riveted 34 Pitch Section	\$73.35
10007411	Chain, D88K Pin & Cotter 34 Pitch Sect	132.68
20001391	Carrier Link, D88K w/ Pin & Cotter	10.44
10001538	Pin & Cotter, Short Teardrop for D88K	1.70
10002235	Pin & Cotter, Long Teardrop for D88K	3.06
10001890	Cotter Only, D88K 1/4 x 3/4in	0.05

If using triangle plates, order short and long teardrop pins.



Inside width 2.5in

### Take-Up Drum (Narrow)

- With weld-in shaft (bearing-style)
- 1 15/16in shaft diameter
- 10 3/16in shaft length
- Use narrow drum with D88K chain



Item #	Description	Price
20002624	Drum, Take-Up Narrow 1 15/16 x 10 3/16in	\$211.02



### SONNY'S Mid-Profile Roller #2 Wheel

Carrier link SC78 included.



New design features larger pusher wheels for a higher profile as compared to a low profile assembly.



Item #	Description	Price
20004527	Roller Assy Sonnys Mid 6Whl #2/SC78 Link	\$54.64

### SONNY'S Low-Profile Roller #3 Wheel

Order carrier link separately.



Item #	Description	Price
20002156	Roller Assy Sonnys Low 6Whl #2 w/Spacers	\$43.94
20001391	Carrier Link, D88K w/ Pin & Cotter	10.44



### SC78 Chain & Carrier Link



Pricing based on minimum 100 feet of chain.

TRAVEL →



Item #	Description	Price
10005314	Chain, SC78 Riveted 16 Pitch Section	\$30.49
10005570	Chain, SC78 Pin & Cotter 16 Pitch Sect	34.59
10003110	Carrier Link, SC78 w/ Pin & Cotter	8.47
10000860	Pin & Cotter Only, SC78 Chain	1.26
10001841	Cotter Only, SC78 Chain 5/32in x 1in	0.11

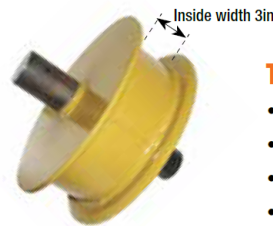

Inside width 3in

### Take-Up Drum (Wide)

- With weld-in shaft (bearing-style)
- 1 15/16in shaft diameter
- 10 3/16in shaft length
- Use wide drum with SC78 chain

Item #	Description	Price
20005311	Drum, Take-Up Wide 1 15/16 x 10 3/16in	\$227.79



### 12-Tooth Drive Exit Sprocket

- For SC78 & D88K chain
- Pitch: 2.609

Heat Treated

20004475

10004235



Item #	Description	Price
20004475	Sprocket, 12 Tooth Taper Lock for Sonnys	\$149.99
10004235	Bushing, 2517 x 2 1/4in Taper Lock	15.15



Heat Treated

### 12-Tooth Take-Up Entrance Sprocket

- With weld-in shaft (bearing-style)
- 1 15/16in shaft diameter
- 10 3/16in shaft length

Item #	Description	Price
20002656	Sprocket, 12 Tooth 1 15/16 x 10 3/16in	\$167.79

## Spring Take-up Fork



Item #	Description	Price
20002550	Conveyor, Fork Roller Up Sonny's Steel	<b>\$136.02</b>

## Spring Take-up Carriage Bolt



Item #	Parts needed to replace spring	Needed	Price
20004755	Conveyor, Spring Tension Bar 18in	1	<b>\$66.34</b>
10004891	100CNFHS Hex Nut Finish 1-8 SS	3	<b>3.99</b>
10000850	WAS1FLLPSS Washer Flat 1in SS	1	<b>0.90</b>
10000773	WAS1SLSS Split Lock Washer 1in SS	1	<b>0.80</b>

## Spring Take-up Spring



Item #	Description	Price
20007191	Spring, Conveyor 16 1/2in x 5in OD	<b>\$91.98</b>

## Spring Take-up Carriage



Item #	Description	Price
20002554	Conveyor, Spring Take-Up Carriage Weld.	<b>\$270.38</b>

## Spring Take-up Fork Hangers with Bushings



Item #	Description	Needed	Price
20003731	Conveyor, Fork Hanger w/ Bushing	2	<b>\$52.49</b>
20003744	Conveyor, Fork Bushing 1 1/4in Sonny's	2	<b>7.56</b>
10004288	50C175HCS5Z Hex Bolt 1/2-13 x 1 3/4 Zc	4	<b>0.42</b>
10001354	50NWSA0Z Washer 1/2in Flat SAE Stl Zc	4	<b>0.05</b>
10001505	50NLOC0Z Washer 1/2in Split Lock Stl Zc	4	<b>0.06</b>
10002309	50CNFH0Z Hex Nut Finish 1/2-13 Zc	4	<b>0.08</b>

## Fork Pivot Bracket, Keystock & Collar



Item #	Description	Price
20003746	Cylinder Fork Pivot Brckt Spring Take-up	<b>\$92.70</b>
10006487	31R200RKS0 Key Stock 5/16 x 2in Stl	<b>1.86</b>
10003082	Collar, 2pc Clamp 1 1/4in Zinc Plated	<b>6.33</b>

## Air Cylinder For Roller-up Spring Take-up Conveyor



- 2in x 8in
- 1/4in Ports
- 7/16in-20 UNF rod thread
- Stainless steel rod with bolt-on rod wiper to improve cylinder's life



Item #	Description	Price
10006949	Cylinder, A350-2 2in Bore x 8in Stk SMC	<b>\$110.00</b>
20010613	Rear Clevis, 1/2in x 2in w/Hardware	<b>26.29</b>
10002001	Elbow, Swivel 3/8in Tube x 1/4in MPT	<b>3.05</b>
10005298	Double Rod Clevis, w/1/2in x 2 1/4in Pin	<b>31.22</b>



## Air Take-up Fork



Air take-up fork shafts manufactured after december 2010 are turned-down to accept air take-up fork hangers with bearings.



Item #	Description	Price
20002510	Conveyor, Triangle Forks Air Take-Up	\$162.17

## Cylinder Fork Pivoting Bracket, Keystock & Collar



20006621



10006487



10003082

Item #	Description	Price
20006621	Cylinder Fork Pivot Bracket Air Take-Up	\$63.98
10006487	31R200RKS0 Key Stock 5/16 x 2in Stl	1.86
10003082	Collar, 2pc Clamp 1 1/4in Zinc Plated	6.33

## Air Take-up Tensioning Shocks & Hose Kit



10007097

2 per box.  
10004339 Kit included.



10003078



10004339

Item #	Description	Price
10007097	Shock, Conveyor Air Tension	\$129.00
10003078	Pin & Cotter, SS 2 1/2in x 5/8in	7.58
10004339	Kit, Air Hose For MA278 & MCNSHK	16.31

## Air Take-up Carriage



Item #	Description	Price
20007295	Conveyor, Air Take-Up Carriage Weldment	\$388.50

## Air Take-up Fork Hangers with Bearings



Replacement item for SONNY'S air take-up conveyor after December 2010



20002480



10006254

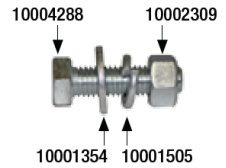

10004288

10002309

10001354

10001505

Item #	Description	Needed	Price
20002480	Hanger, Fork 1 1/4in Bearing Assembly	2	\$106.15
10006254	Bearing, 3Bolt Flange 1.25in /Conv Fork	2	59.25
10004288	50C175HCS5Z Hex Bolt 1/2-13 x 1 3/4 Zc	4	0.42
10001354	50NWSA0Z Washer 1/2in Flat SAE Stl Zc	4	0.05
10001505	50NLOC0Z Washer 1/2in Split Lock Stl Zc	4	0.06
10002309	50CNFH0Z Hex Nut Finish 1/2-13 Zc	4	0.08

## Air Take-up Fork Hangers (Fall of 2007 to Spring of 2008)

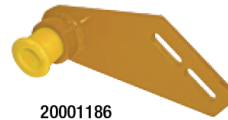

20001186



20003699

Item #	Description	Price
20001186	Fork Hanger w/Bushing, DS Air Take-Up	\$41.20
20003699	Fork Hanger w/Bushing, PS Air Take-Up	41.20

For mounting hardware, refer to section directly above this one.

## Air Take-up Fork Kick Plate



Item #	Description	Price
20001703	Conveyor, Air Take-Up Fork Kick Plate	\$54.08

## Air Take-up Chain Guide

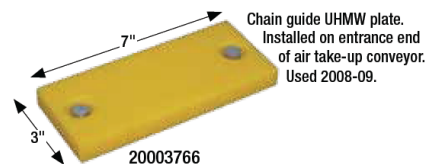

20003766

Chain guide UHMW plate.  
Installed on entrance end  
of air take-up conveyor.  
Used 2008-09.

Item #	Description	Price
20003766	Conveyor, Chain Guide Assy w/ Hardware	\$27.68

## Air Cylinder For SONNY'S Roller-up / Air Take-up Conveyor



- 1 1/2in x 6in • 1/4in ports • 7/16 in-20 UNF rod thread
- Stainless steel rod with bolt-on rod wiper to improve cylinder's life

If replacing an A700 ARO square cylinder, you will need to order the new style upgrade kit (20002636). Kit comes completely assembled and ready to be bolted in place with included hardware.

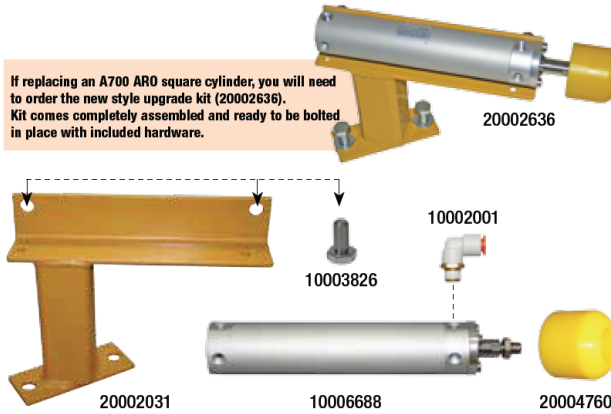

Item #	Description	Price
20002636	Cylinder Upgrade Kit Complete New Style	<b>\$166.06</b>
20002031	Mounting Bracket Only Roller Up Cylinder	<b>44.12</b>
10006688	Cylinder, A550 1.5in Bore x 6in Stk SMC	<b>78.98</b>
10003826	Bolt, Hex M10 125P x 20mm	<b>0.49</b>
10002001	Elbow, Swivel 3/8in Tube x 1/4in MPT	<b>3.05</b>
20004760	Cap Only, UHMW Air Roller Up	<b>8.61</b>

## SONNY'S Air Shock Conveyor Chain Tension Take-Up Conversion Kit



- Replaces standard spring and tension bolt on an existing SONNY'S Roller-On-Demand Over-Under Conveyor
- Works with SC78, D88K, X458, LOG Chain - (chain, rollers, carrier links, sprocket and drum not included)
- Allows for quick, tool-free release of chain tension for easy maintenance, adjustment, and repair
- Includes fork mounts, air shocks, collars, mounting clips, control panel, carriage, cylinder mount, air manifolds, pins, and cotters necessary for a complete conversion

Item #	Description	Price
20003433	Conveyor, Air Conversion Kit	<b>\$2,055.00</b>



## Valve for Air Take-up Panel



- 1/8in orifice - 24CFM at 125PSI
- 2 or 3 way
- Normally closed only
- Positive detent in closed and open position
- Mount in any position

Item #	Description	Price
10006049	Manual Valve, 3Way 2 Position 1/8in FPT	<b>\$52.42</b>

## Pressure Switch

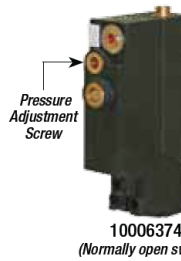

The pressure air safety switch will ensure that if the chain has less than 30PSI the conveyor will not run. Pressure switch must be wired to a low air fault or E-Stop.

- Adjustable Trip Pressure: 30-70PSI (2 to 5 Bar)
- Insulation Voltage: 250V AC or DC
- Ports: 1/8in for Semi-Rigid Nylon or Polyurethane Tube
- Mounting: Inline or 35mm DIN Rail

Item #	Description	Price
10006374	Parker Low Air Pressure Switch 30-75PSI	<b>\$60.00</b>

20007049 (complete)



## Air Take-up Manifold

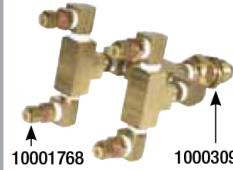

- Connects all four ports to tensioning shocks
- 3/8in tube supply line to air manifold
- 1/8in tube connection to each shock

Item #	Description	Price
20007049	Conveyor, Air Manifold Assembly	<b>\$93.54</b>
10001768	Connector, Brass Push 1/8 Tube x 1/8 MPT	<b>2.66</b>
10003092	Union, Bulkhead 3/8in Tube x 1/4in FPT	<b>7.80</b>



The air take-up should have 40 to 50PSI set at the air regulator.

## Air Take-up Panel

- Air Supply: 3/8in tube
- Includes pressure switch
- Pressure switch should be wired to your E-Stop or low air fault

Item #	Description	Price
20010207	Conveyor, Safety Control Panel Assy	<b>\$415.00</b>

### Log Chain 11 link

- 5/8in diameter
- Grade 70
- 3.50in pitch
- Proof Test - 40,000 lbs.



10004989



10002311



20000471  
Optional 5/8in round plug  
used to weld log links closed

Item #	Description	Price
10004989	Chain, Log 11 Link Length 3 1/2 Pitch	\$28.83
20010473*	Chain, Log 7 Link Length 3 1/2in Pitch	27.99
20003705*	Chain, Log 9 Link Length 3 1/2in Pitch	23.38
10002311	Chain, Loose Link Only Heat Treated	6.27
20000471	Bar, 5/8 Rd x 5/8 CRS	1.37

\* 7 and 9 link increments used to shorten chain for proper tension

### 4-Tooth Drive Sprocket & Taper Lock for Log Chain

Hardened steel sprocket.



20002860



10004235

Item #	Description	Price
20002860	Sprocket, 4 Tooth Taper Lock Log Chain	\$313.95
10004235	Bushing, 2517 x 2 1/4in Taper Lock	15.15

### Log Chain Take-up Drum

- With weld-in shaft (bearing-style)
- 1 15/16in shaft diameter
- 10 3/16in shaft length
- Hardened steel drum



Item #	Description	Price
20003036	Drum, Take-Up Log Link Conveyor	\$430.50



### SONNY'S Roller for Air Take-up with Log Chain Link



Item #	Description	Price
20004417	Roller Assy Sonny's 4Wheel w/Log Link	\$57.77

### Electric Drive Motor and Gear Box



The electric Drive Motor and Gear Box, is an alternate option for hydraulic power on all SONNY'S conveyors.

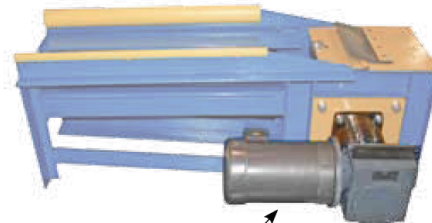

10008760  
5HP shown

10009270

Item #	Description	VFD*	Price
10008622	Motor, 3HP Washdown 182TC	50-120CPH	\$625.00
10008760	Motor, 5HP 1800RPM Washdown 184TC	100-160CPH	709.15
10009270	Gearbox, Center Flange Keyed OP Electric	-	2,687.10

\*VFD = Variable Frequency Drive

### Conveyor Chain Speed Guide

Distances shown are for the travel of 1 conveyor roller in 15 seconds.

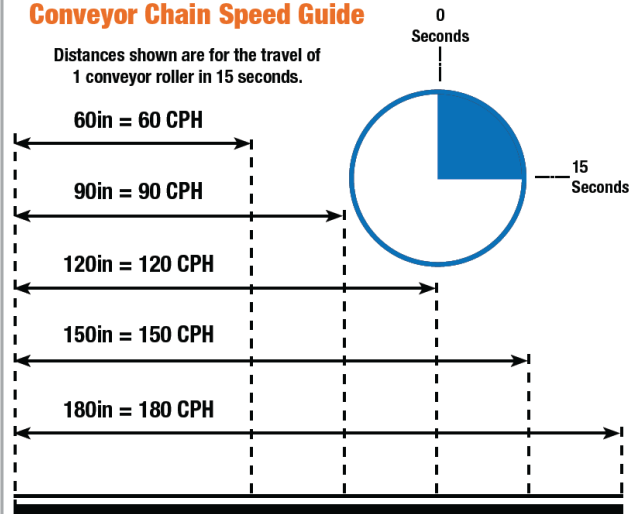

CPH = Cars Per Hour

## CX458 Chain & Carrier Link



Pricing based on minimum order of 100 feet of chain.



Item #	Description	Price
10003565	Chain, X458 4in Pitch, 10ft Section	<b>\$78.38</b>
10002030	Chain, X458 Center Link Only	<b>3.15</b>
10002055	Chain, X458 Side Bar Only	<b>4.36</b>
10001289	Chain, X458 Pin Only	<b>1.37</b>

### For CX458 style chain only:

- 11 Chain link increments for 3 feet 8in roller spacing (11 increments between rollers)
- 23 Chain link increments for 7 feet 4in roller spacing (23 increments between rollers)

## 4-Tooth Sprocket & Taper Lock for CX458 Chain



Item #	Description	Price
20005338	Sprocket, 4 Tooth Taper Lock X458	<b>\$246.48</b>
10004235	Bushing, 2517 x 2 1/4in Taper Lock	<b>15.15</b>

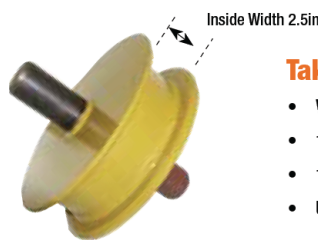

## Take-up Drum (Narrow)

- With weld-in shaft (bearing-style)
- 1 15/16in shaft diameter
- 10 3/16in shaft length
- Use narrow drum with CX458 chain

Item #	Description	Price
20002624	Drum, Take-Up Narrow 1 15/16 x 10 3/16in	<b>\$211.02</b>



## SONNY'S Roller for Air Take-up with CX458 Chain Link

Item #	Description	Price
20002253	Roller Assy Sonny's 4Wheel w/X458 Link	<b>\$55.06</b>

## SONNY'S Mid Profile & Carrier Link



Item #	Description	Price
20002233	Roller Assy Sonny's Mid 6Whl #2 w/Spacers	<b>\$49.01</b>
20007112	Carrier Link, X458 for Sonny's	<b>9.50</b>

## Kick Off Plate



Guides vehicle tire off at the exit end of the conveyor for a smoother transition. Should be used with front wheel pull, surface conveyors and when there is an uphill slope.



Item #	Description	Price
20003743	Kick off Plate, 5ft Conveyor	<b>\$465.00</b>



## SONNY'S Conveyor Tracking Bars

- Recommended for all surface and front wheel pull over-under conveyors
- Guides vehicle through tunnel and reduces any potential for vehicle to jump off the conveyor

Item #	Description	Price
20006441	Tracking Bar Rails, 10ft x 24in Section	<b>\$173.04</b>



## **\*WARRANTY\***

### **SONNY'S ENTERPRISES, INC. FACTORY LIMITED LIFETIME WARRANTY**

Equipment manufactured by SONNY'S ENTERPRISES, INC. is warranted to be free from defect in material and workmanship. Welded metal framework and other non-moving, non-wearable fabricated metal components manufactured by SONNY'S are warranted for the life of the equipment to the original purchaser. Fabricated metal wearable surface and moving components manufactured by SONNY'S are warranted for a period of one (1) year to the original purchaser of the equipment.

All components assembled to SONNY'S equipment that are manufactured by others are warranted by the appropriate manufacturer and subject to that manufacturer's limited warranty. Contact SONNY'S for the specific information on other component manufacturer's warranty terms. All new PermaColor™ cloth shipped with new SONNY'S equipment is warranted for a period of one (1) year, or 100,000 Car Washes, whichever occurs first. All new MicroClean™ Wash Material shipped with new SONNY'S equipment is warranted for a period of one (1) year, or 60,000 Car Washes, whichever occurs first.

This warranty is not assignable or transferable. The warranty period begins the first day following installation or 30 days from the original invoice date, whichever occurs first. The Seller's liability shall be limited to repair or replacement of materials found to be defective within the warranty period. In the event of repair or replacement this limited warranty is noncumulative. The Purchaser must supply the Seller with immediate written notice when any defects are found. The Seller shall have the option of requiring the return of defective material to establish the Purchaser's claim. Neither labor nor transportation charges are included in this warranty. Transportation damage claims are to be submitted to the carrier of the damaged materials.

This warranty is based upon the Purchaser's reasonable care and maintenance of the warranted equipment. It does not apply to any equipment which has been subject to misuse, including neglect, accident, or exposure to harsh chemicals, including but not limited to Hydrofluoric Acid • Ammonium Bi-fluoride • Bromic Acid • Muriatic Acid • Sulfonic Acid • Phosphoric Acid • Hydrogen Cyanide • Hydrochloric Acid • Chlorinated Solvents. Nor does it apply to any equipment which has been repaired or altered by anyone not so authorized by SONNY'S. Further, the equipment must be properly installed with proper accuracy of all specified plumbing, electrical, and mechanical requirements. This warranty does not apply to normal wear and tear or routine maintenance components.

EXCEPT AS EXPRESSLY STATED HEREIN, SONNY'S SHALL NOT BE LIABLE FOR DAMAGES OF ANY KIND IN CONNECTION WITH THE PURCHASE, MAINTENANCE, OR USE OF THIS EQUIPMENT INCLUDING LOSS OF PROFITS AND ALL CLAIMS FOR CONSEQUENTIAL DAMAGES. THE LIMITED WARRANTY EXPRESSED HEREIN IS IN LIEU OF ALL OTHER WARRANTIES EXPRESSED OR IMPLIED. SONNY'S NEITHER ASSUMES NOR AUTHORIZES ANY PERSON TO ASSUME FOR IT ANY OTHER OBLIGATION OR LIABILITY IN CONNECTION HEREWITH.



## \*CUSTOMER SERVICE\*

Please contact SONNY'S Equipment Department for installation and/or operational questions regarding this piece of equipment.

Please refer to the Parts list in this manual or our Parts Catalog and contact SONNY'S Customer Service Order Entry Department for any replacement parts for this piece of equipment.

For Equipment Repairs please visit the web at [www.sonnysdirect.com](http://www.sonnysdirect.com).

DEPARTMENT	PHONE NUMBERS	FAX NUMBERS
Toll Free Main Line	800-327-8723	800-495-4049
Equipment Department	954-720-4100	954-720-9292

Or you can email Sales at [sales@sonnysdirect.com](mailto:sales@sonnysdirect.com)

*Thank you for being a SONNY'S car wash equipment owner!*

*From all of us here at*

