

# SUPPORT EQUIPMENT

## SONNY'S CENTRAL VACUUM SYSTEMS

### Our Central Vacuum Systems will Never Let you Down



#### Problem:

You need to provide your customers with convenient, powerful vacuum stations through a centralized system that is reliable and easy to maintain.

#### Solved:

SONNY'S Central Vacuum Systems come in all different sizes from 10HP up to 30HP and can support up to 10 drops on one single system. Our vacuum systems are completely built in-house and all impellers are high-speed balanced for total quality control. We never want you to be down, so in the rare event that something should go wrong with your central vacuum turbine, SONNYS offers the only turbine swap program in the industry to keep you running while yours is being serviced.

#### Quiet and Efficient

- Turbine aluminum casting 1/2in thick for strength, and heat displacement
- Heavy-duty cast iron motor TEFC 208V / 230V / 460V
- 2-year warranty on high-efficiency motor
- Turbine impeller-rotating assembly – supported by (2) precision 4-bolt SealMaster® flanged bearings with zircon fittings for lubrication
- Backward curve impeller design for greater efficiency
- Vacuum separator – 12-gauge steel
- Automotive-type paint finish inside & out
- Polypropylene, corrosion-resistant, 11gal waste bucket
- High-altitude units available on request



6in connection points inlet / outlet for vacuum separator.



Exclusive double latching door provides positive seal for improved performance.



Included coupler guard provides effective safety barrier that is quick to remove when necessary.



Backward curve impeller design for greater efficiency.



Polypropylene, corrosion-resistant, 11gal waste bucket.



New and improved composite metal bag holder

CALL: 800-327-8723 FAX: 800-495-4049

[www.SonnysDirect.com](http://www.SonnysDirect.com)

**The Tunnel Experts™**

**SONNY'S®**  
The CarWash Factory

# SONNY'S CENTRAL VACUUM SYSTEMS

For in-depth information about this product, watch video at [www.sonnysdirect.com](http://www.sonnysdirect.com)

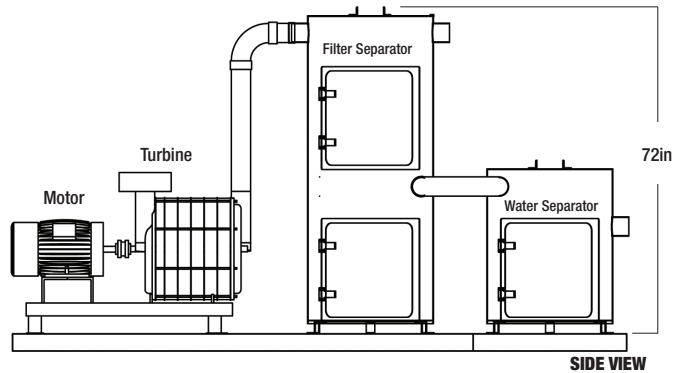
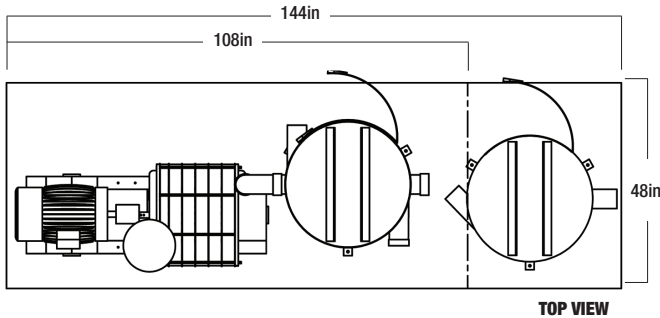

## Central Vacuum Turbine and Motor

Item #	Description	HP	Drops	#Stages	Weight	ICFMC	HG	Price
20003602	Vac, 10HP Turbine & Motor Set up No Tank	10	2-4	3	494lbs	435	4in	<b>\$3842.03</b>
20003613	Vac, 15HP Turbine & Motor Set up No Tank	15	4-6	4	626lbs	550	5-1/2in	<b>\$4864.76</b>
20003630	Vac, 20HP Turbine & Motor Set up No Tank	20	6-8	5	705lbs	625	6in	<b>\$5029.02</b>
20003646	Vac, 25HP Turbine & Motor Set up No Tank	25	10-12	6	706lbs	750	7in	<b>\$5538.10</b>
20015051	Vac, 30HP Turbine & Motor Set up No Tank	30	12-14	7	867lbs	875	9in	<b>\$9000.00</b>

**NOTE:** When ordering dual turbine, Order (2) turbines and motor configurations of the same HP. Only one separator is needed for dual configuration. On a dual configuration, order (2) 4in swing check valves (#10006225) for complete plumbing connection to the single separator.

## Specifications

	Footprint	Height	Inlet	Outlet	Weight
Filter Separator	42in x 52in	76in	(2) at 4in OD	(2) at 4in OD	328lb
Water Separator	42in x 52in	52in	(2) at 4in OD	(2) at 4in OD	200lb
Turbine Pedestal	57in L X 25in W	42in	-	-	-
Lift Kit	62in L X 22in W	15in	-	-	154lb

## Vacuum Filter Separator

Designed to collect all dirt and debris from the vacuum manifolds into an 11 gal debris tank on the bottom half. On the top half, air goes through 10 three micron filter bags, allowing for the cleanest air to go through your vacuum turbine.



\* A single separator can support a maximum of (2) 20HP turbines and motors.

## Central Vacuum Accessories

Item #	Description	Price
20015098	Vacuum, Separator Universal W/10 Bags	<b>\$2900.00</b>
20004374	Tank Water Separator SS	<b>\$3936.24</b>
20005494	Vacuum, Central Base Lift Kit	<b>\$515.00</b>
20005493	Vacuum Turbine Silencer Muffler 4in O.D.	<b>\$274.80</b>
20004942	Vacuum Turbine Cast Exhaust Hood 4.36in	<b>\$42.75</b>
10000252	Muffler, Vacuum Silencer 6" 30HP	<b>\$550.00</b>
10012041	Vacuum, Muffler Rain Cap 6in	<b>\$25.00</b>

## Optional Silencer



For quiet operation of your SONNY'S vacuum system. Silencer's (#20005493) 4in or (#10000252) 6in outside diameter allows for an easy attachment to the exhaust of your turbine using a no hub coupler. The exhaust hood prevents rain from getting into exhaust muffler and turbine.

## Optional Water Separation Tank



It's like buying insurance for your central vacuum system. Ideal for snow or other wet conditions and underground piping. Keeps filter in driest condition and prevents bags from clogging.

20004374

## Optional Turbine Lift Kit

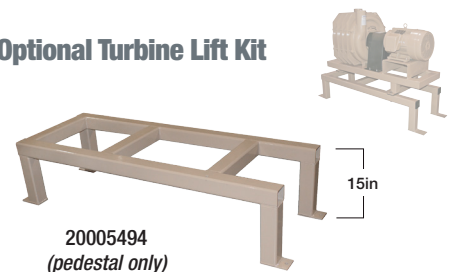

The Lift Kit raises the motor and turbine pedestal an additional 15in off the ground, ideal for areas with high water or snow.

SONNY'S is the World's Bestselling Conveyorized Car Wash Equipment, Designed and Built in the USA and in Stock for Immediate Delivery

Designed Here. Built Here. Backed Here.

