

L3 / L4 ARCH INSTALLATION

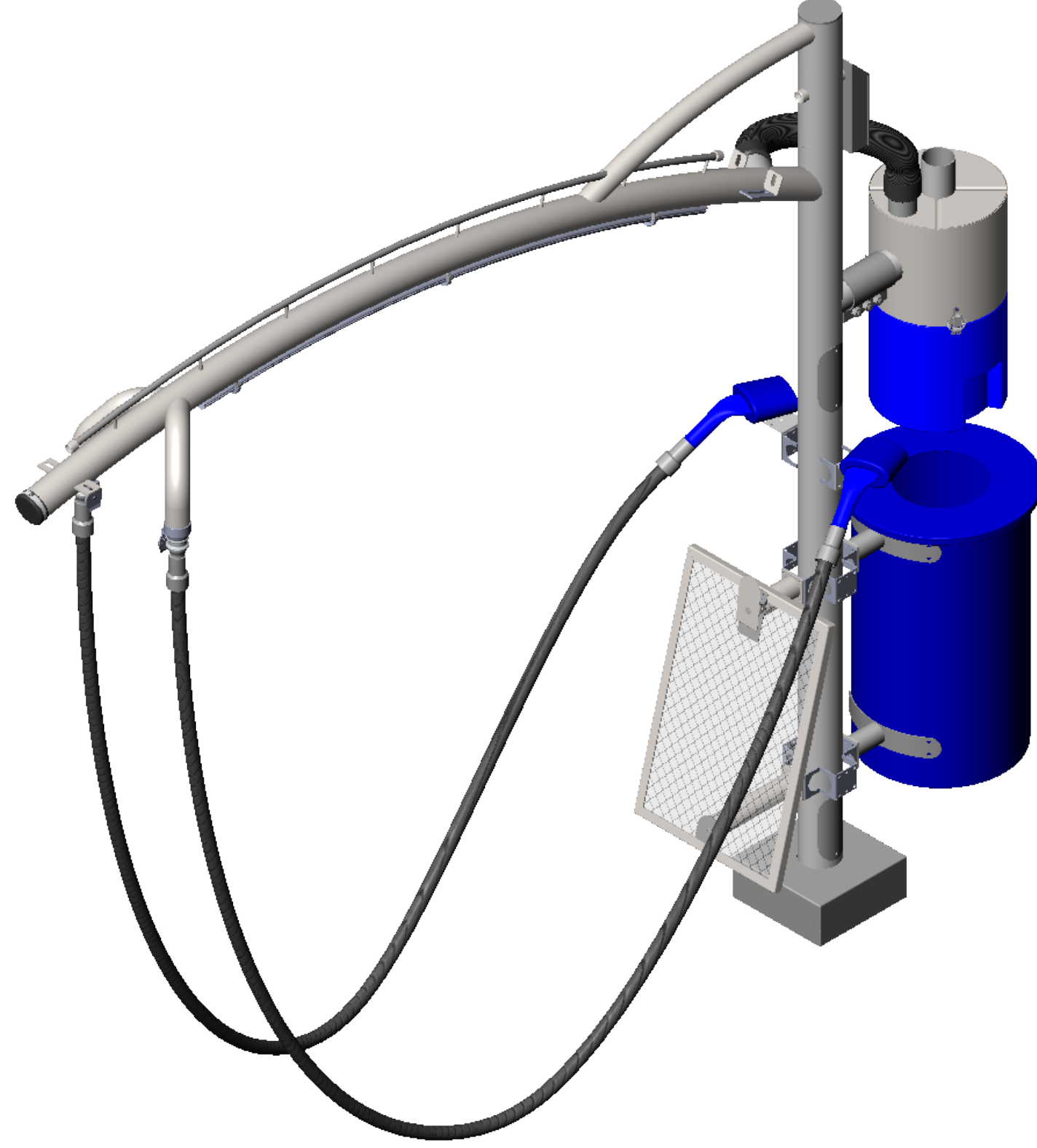

PROJECT TITLE:

**INS - P&S - INSTALL
L3/L4 ARCH**

PROJECT ADDRESS:

DRAWN BY:

ER

REV:

A

CLIENT APPROVAL

PROJECT NO.:

SIGNATURE AND DATE:

888-628-8682

www.autovacinc.com

sales@autovacinc.com

AUTOVAC
Industrial
Vacuum & Air systems

INSTALLATION INSTRUCTIONS

THE POST MAY BE INSTALLED AT VARIOUS ANGLES

ALIGN USING THE PAINTED PARKING LINE OR CURB AS A POINT OF REFERENCE

INSTALL ANCHOR BOLTS IN ACCORDANCE TO HOW THE BASEPLATE WILL BE ORIENTED / ANGLED (HARDWARE NOT INCLUDED)

UPRIGHT POST AND BASEPLATE

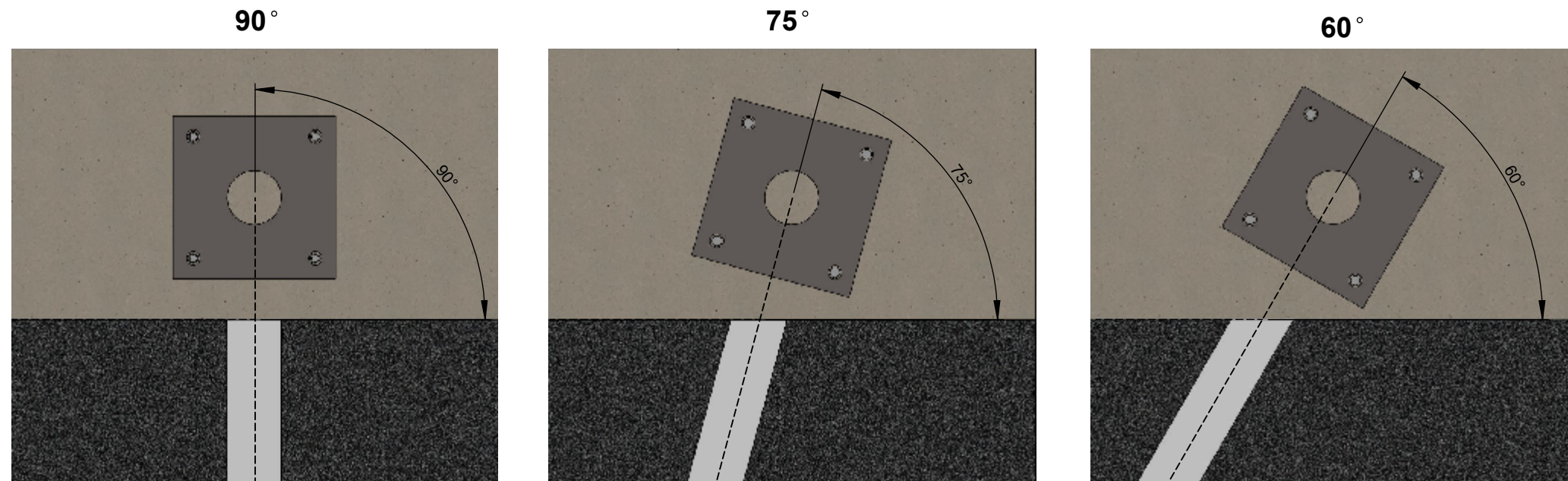

① SET VERTICAL POST IN FOOTING AND BOLT BASE PLATE DOWN TO EXISTING ANCHOR BOLTS (HARDWARE NOT PROVIDED)

USE WASHERS AND/OR LEVELING NUTS TO MAKE POST PLUMB

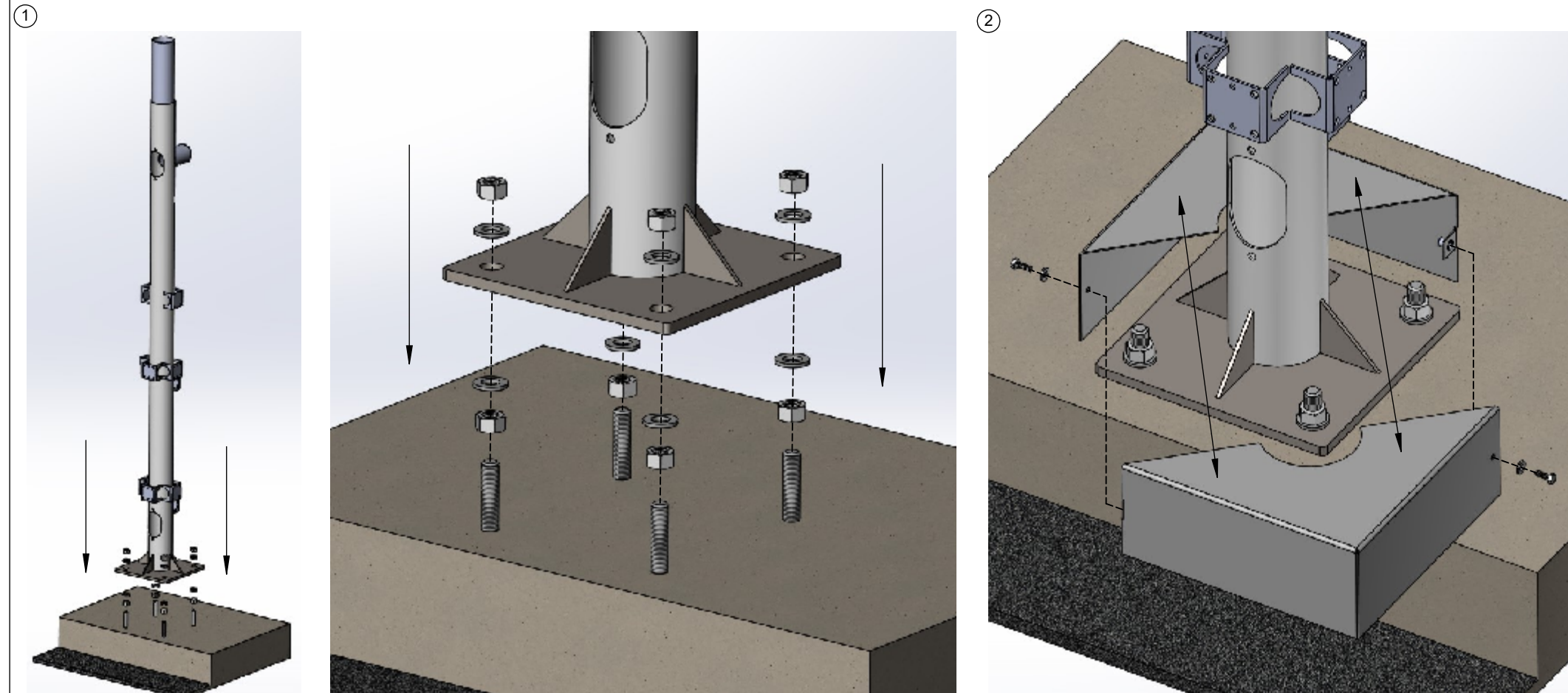

② BOLT TOGETHER BOTH HALVES OF THE BASE PLATE COVERS

HAND TIGHTEN TO LOCK (DO NOT USE POWER OR PNEUMATIC TOOLS)

HARDWARE:
BOLT: 1/4 - 20 X 3/4" : 2 PER SET
FLAT WASHER: 1/4" : 2 PER SET



888-628-8682
www.autovacinc.com
sales@autovacinc.com

CLIENT APPROVAL

PROJECT NO.:

DRAWN BY: ER

SIGNATURE AND DATE:

REV: A

PROJECT TITLE:
INS - P&S - INSTALL UPRIGHT POST & BASEPLATE

PROJECT ADDRESS:

INSTALLATION INSTRUCTIONS

- ① INSTALL JIM CAP ONTO THE END OF THE ARCH *
TIGHTEN HOSE CLAMP TO HOLD IN PLACE

- ② INSTALL INLET VALVES INTO THREADED FITTINGS ON ARCH *

APPLY TEFLON THREAD TAPE AROUND INLET VALVE THREADS TO PREVENT VACUUM LEAKS PRIOR TO INSTALLING

TIGHTEN BY HAND OR BY USING A WRENCH AROUND THE COLLAR ONLY

DO NOT USE THE CAP/LID AS LEVERAGE TO TIGHTEN - DOING SO MAY BEND IT AND CAUSE VACUUM LEAKS

* THESE ITEMS MAY COME PRE INSTALLED FROM THE FACTORY

- ③ SET THE ARCH ON THE POST, MAKING SURE IT SLIDES COMPLETELY DOWN THE SLEEVE

ADJUST ANGLE OF ARCH TO BE PARALLEL WITH THE PARKING LANE

INSTALL BOLTS AND TIGHTEN TO LOCK ARCH POSITION

HARDWARE:
BOLT: 3/8-16 X 1" : 2 PER SET

L3 / L4 ARCH

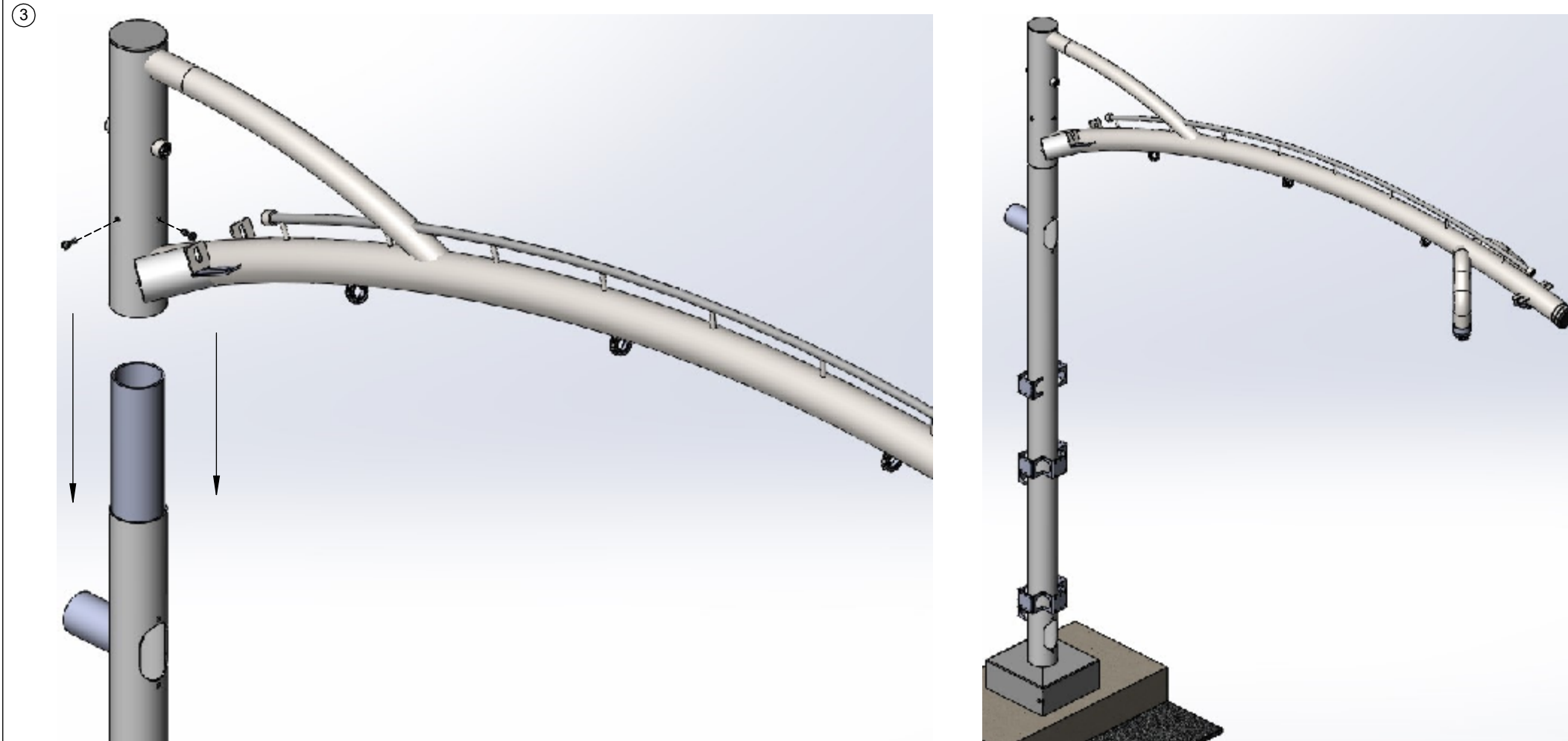
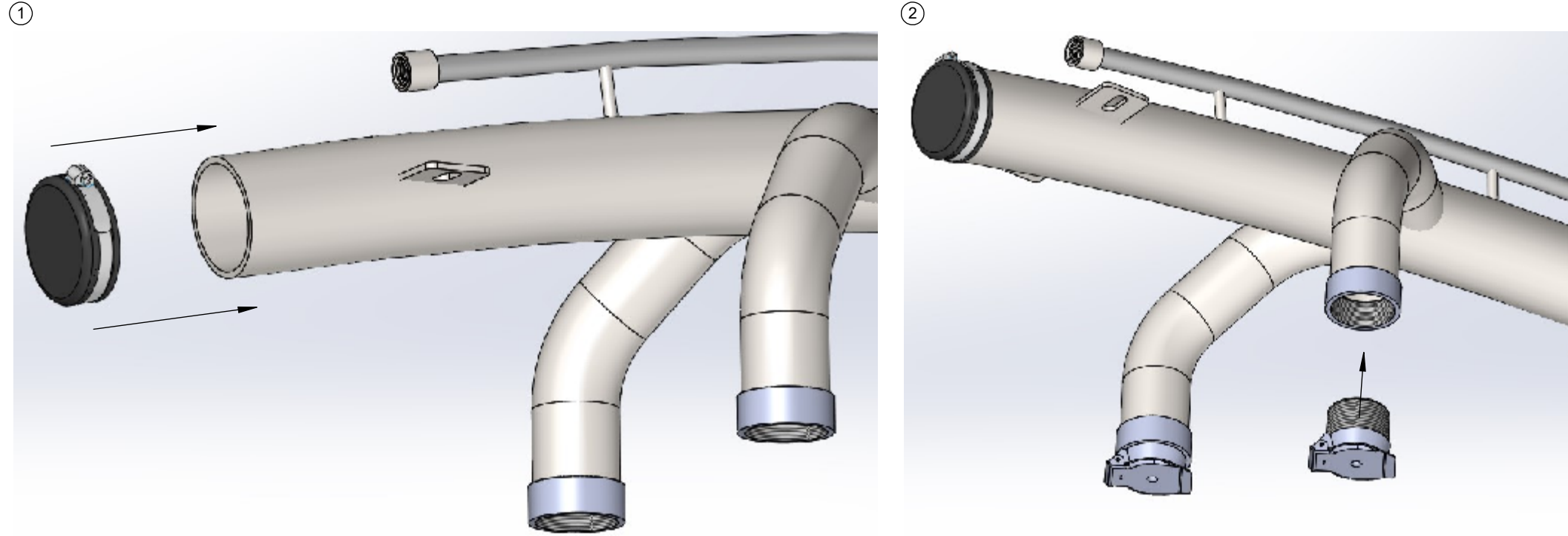

CLIENT APPROVAL

PROJECT NO.:

SIGNATURE AND DATE:

DRAWN BY:

ER

REV:

A

PROJECT TITLE:
**INS - P&S - INSTALL
L3/L4 ARCH**

PROJECT ADDRESS:

INSTALLATION INSTRUCTIONS

CYCLONIC SEPARATOR

①

SLIDE COMPRESSION COUPLING ONTO PROTRUDING HORIZONTAL POST MAKING SURE INTERNAL RUBBER SLEEVE IS INTACT

LIFT METAL SEPARATOR TO POST AND INSERT PIPE STUB INTO COMPRESSION COUPLING. USE CARE TO AVOID WRINKLING OR OVERLAPPING THE INTERNAL RUBBER SLEEVE

VERIFY THAT SEPARATOR IS LEVEL AND COMPRESSION COUPLING IS CENTERED OVER THE POINT WHERE BOTH TUBES ARE BUTTED

TIGHTEN COUPLER NUTS PARTIALLY IN A UNIFORM MANNER TO ASSURE PROPER SEATING OF THE INNER SLEEVE AND GASKET

FULLY TIGHTEN AND TORQUE NUTS TO **65 FT LBS.**

①

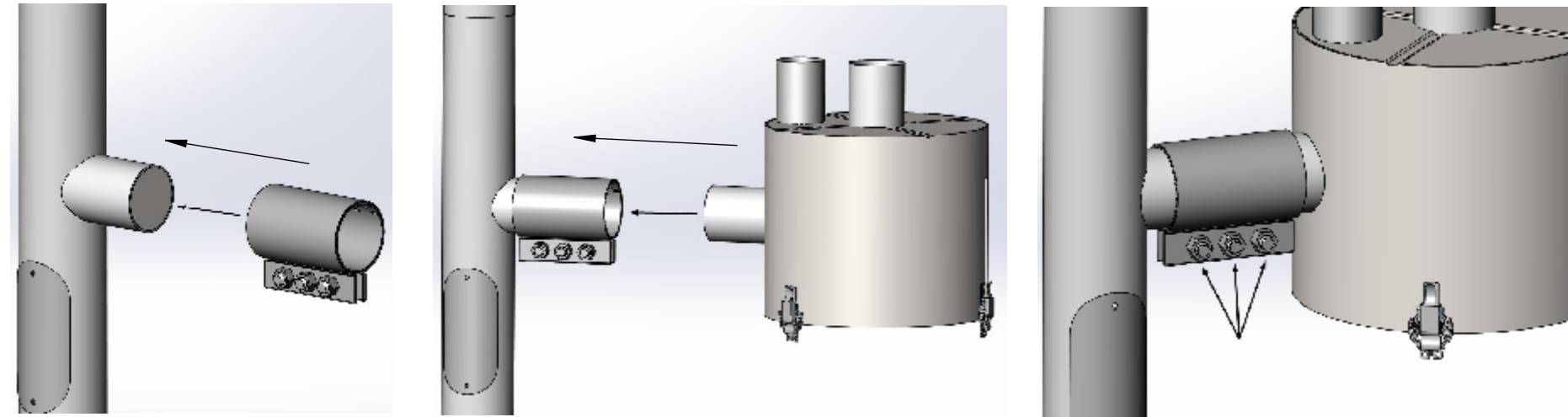

②

LIFT PLASTIC DEBRIS BUCKET UP TO SEPARATOR ALIGNING THE THREE (3) LATCHES WITH THEIR STRIKE PLATES

SECURE BUCKET BY APPLYING LATCHES

②

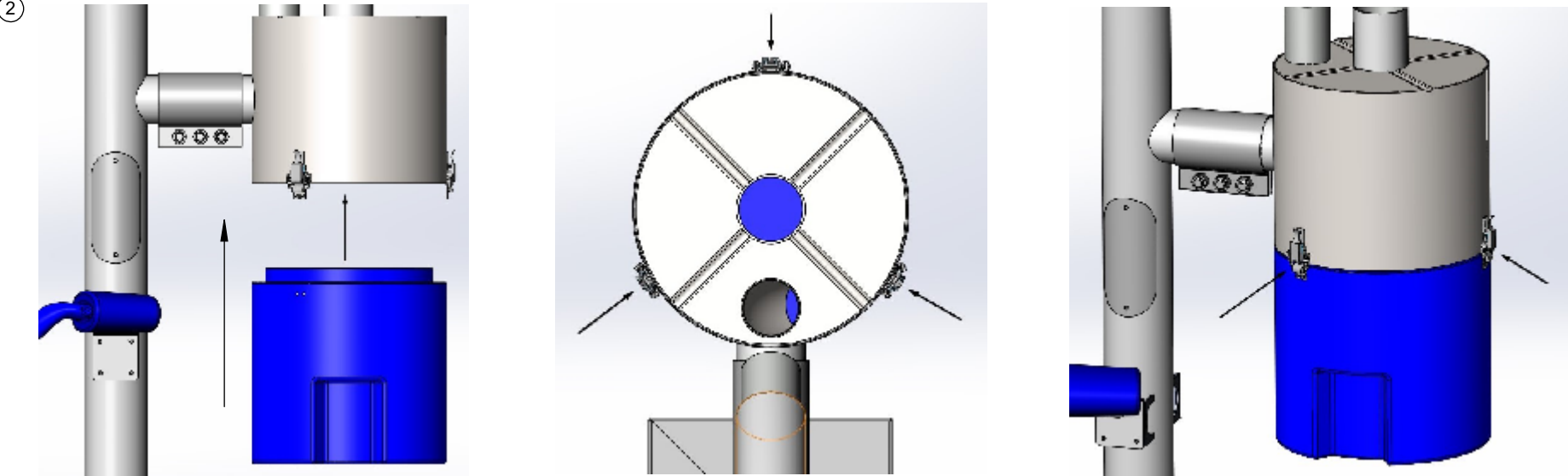

③

FOR VACUUM ARCHES

INSTALL 3" FLEXIBLE VACUUM HOSE CONNECTING THE CYCLONIC SEPARATOR TO THE VACUUM ARCH STRUCTURE

③



AUTOMAC
Industrial
Vacuum & Air systems

888-628-8682
www.autovacinc.com
sales@autovacinc.com

CLIENT APPROVAL

PROJECT NO.:

SIGNATURE AND DATE:

DRAWN BY:

ER

REV:

A

PROJECT TITLE:

**INS - P&S - INSTALL
CYCLONIC SEPARATOR**

PROJECT ADDRESS:

INSTALLATION INSTRUCTIONS

① ASSEMBLE MAT HOLDER BEFORE ATTACHING TO ARCH OR STANCHION

ATTACH MAT HOLDER CLAMP AND SPACER A TO MAT HOLDER FRAME AS PICTURED USING TWO 1/4" HEX HEAD BOLTS AND WASHERS

ATTACH SPACER B TO MAT HOLDER FRAME USING ONE 1/4" HEX HEAD BOLT AND WASHER

HAND TIGHTEN TO LOCK
(DO NOT USE POWER OR PNEUMATIC TOOLS)

MAT HOLDER

①

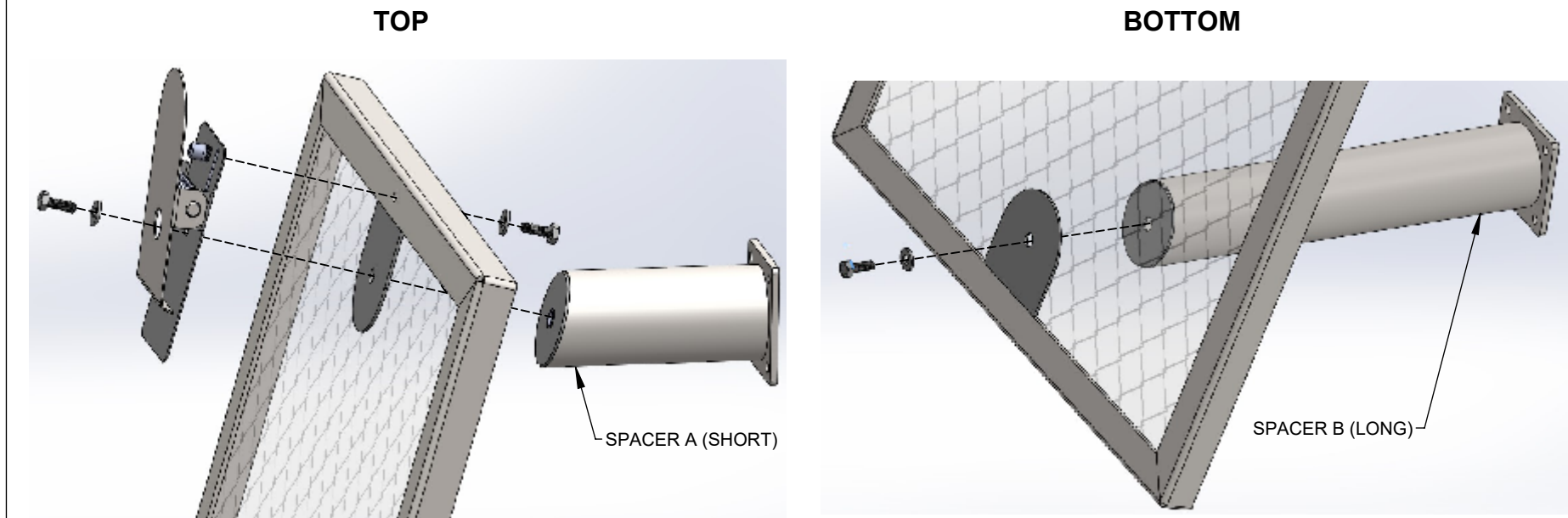

② INSTALL 1/4" HEX HEAD BOLTS WITH WASHERS IN POST BRACKET (4 BOLTS / WASHERS PER BRACKET). TIGHTEN TO LOCK

HAND TIGHTEN TO LOCK
(DO NOT USE POWER OR PNEUMATIC TOOLS)

TWO (2) BRACKETS ARE NEEDED PER MAT HOLDER

②

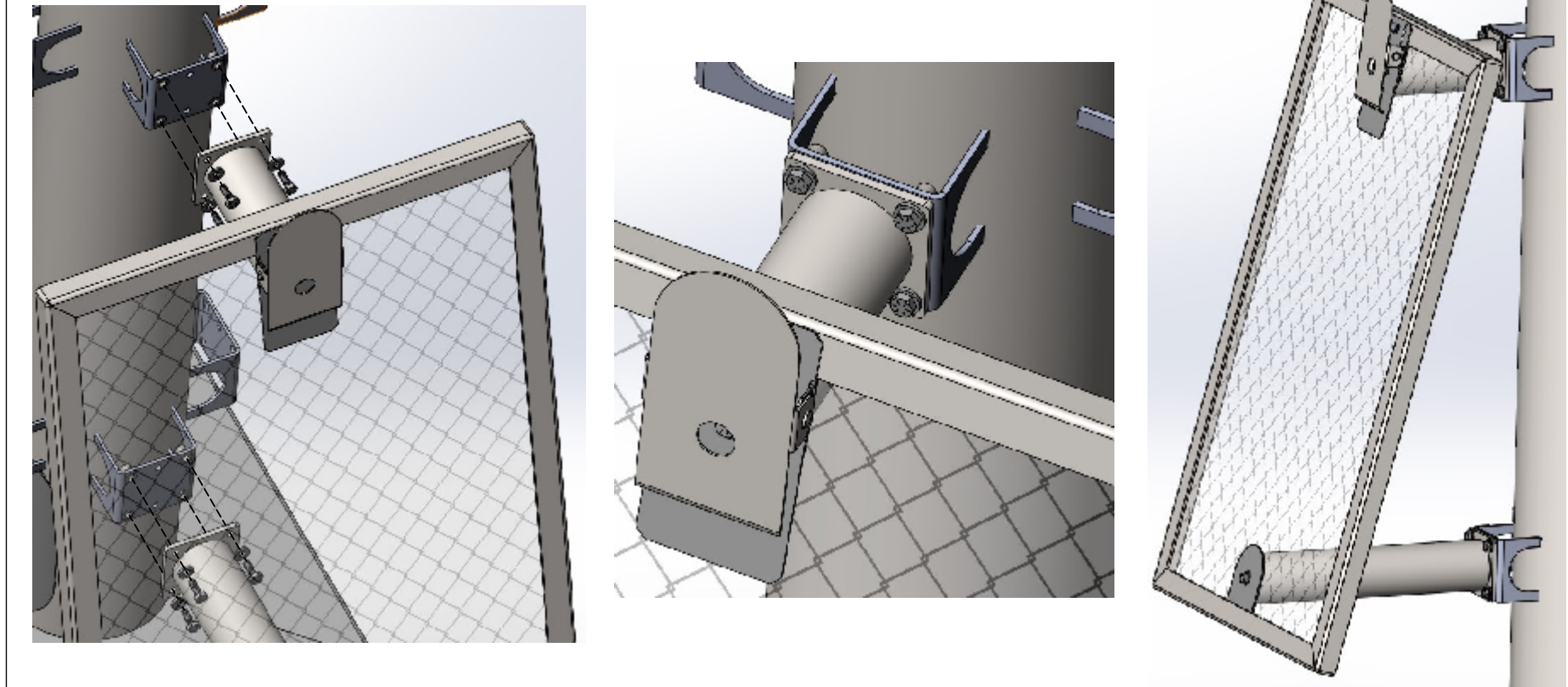

888-628-8682
www.autovacinc.com
sales@autovacinc.com

CLIENT APPROVAL

PROJECT NO.:

DRAWN BY: ER

SIGNATURE AND DATE:

REV: A

PROJECT TITLE:
**INS - P&S - INSTALL
MAT HOLDER**

PROJECT ADDRESS:

DETACHABLE BRACKET INSTRUCTIONS

TRASH CAN

- ① INSTALL SHOULDER BOLTS IN POST BRACKET (4 BOLTS PER BRACKET)

HAND TIGHTEN TO LOCK
(DO NOT USE POWER OR PNEUMATIC TOOLS)

TWO (2) BRACKETS ARE NEEDED PER TRASH CAN

①

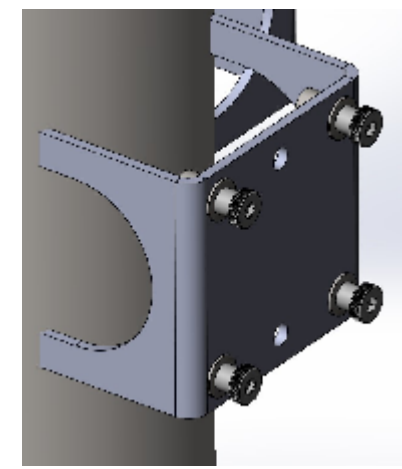
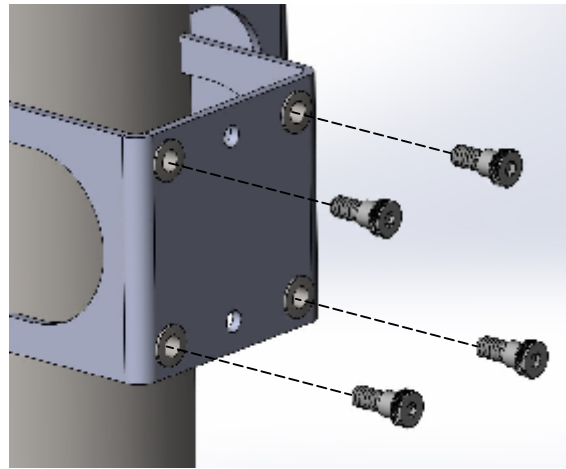

- ② *OPTIONAL* FOR TIGHTER FITMENT

INSTALL SHOULDER BOLTS IN POST BRACKET
(4 BOLTS, 4 FLAT WASHERS PER BRACKET)

MAKE SURE FLAT WASHERS DO NOT GET FIXED BY THE SHOULDER BOLT
TO THE BRACKET

HAND TIGHTEN TO LOCK
(DO NOT USE POWER OR PNEUMATIC TOOLS)

②

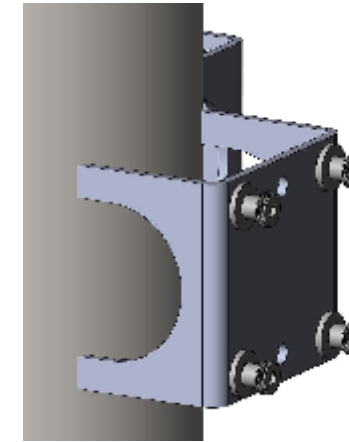
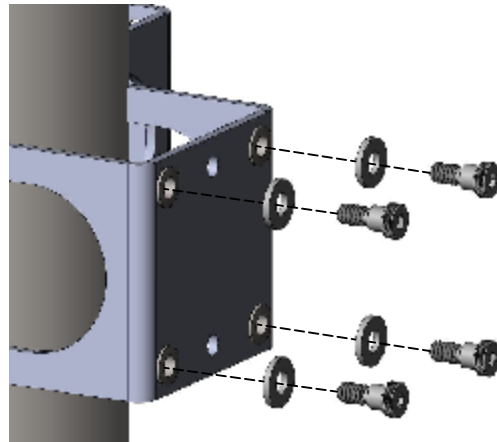

- ③ BOLT BRACKET TO PLASTIC CONTAINER
(4 HEX HEAD BOLTS, 4 FLAT WASHERS PER BRACKET)

HAND TIGHTEN TO LOCK (DO NOT USE POWER OR PNEUMATIC TOOLS)

MAY ALREADY COME INSTALLED FROM FACTORY

- ④ INSERT BRACKET ONTO SHOULDER BOLTS

MAKE SURE ALL BOLT HEADS ARE FULLY INSERTED IN BRACKET HOLES

③

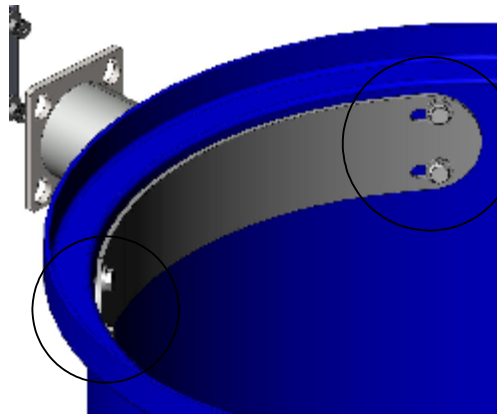

④

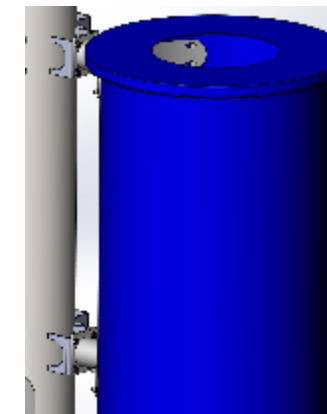
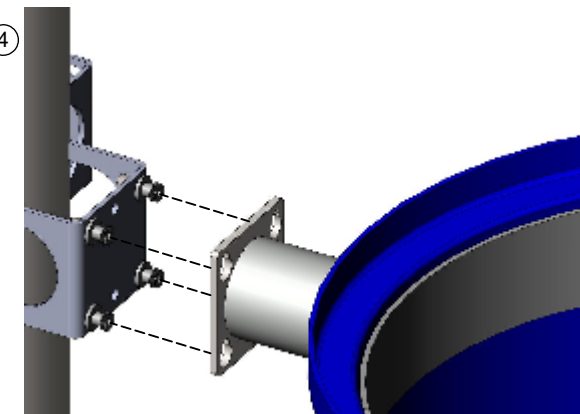

- ⑤ SLIDE BRACKET DOWN TO LOCK IN PLACE

TO REMOVE OR CLEAN CONTAINERS

SLIDE UP BRACKET TO UNLOCK AND DETACH FROM POST

⑤

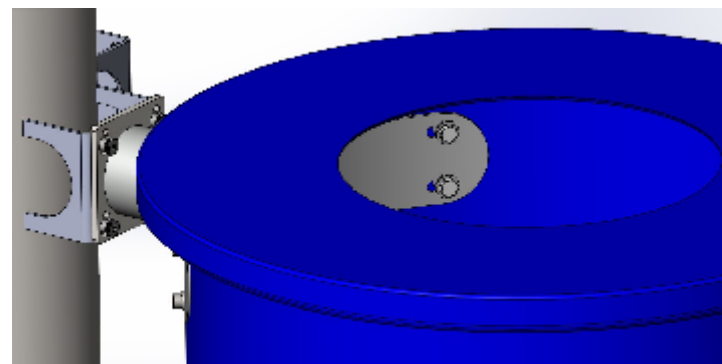

⑤

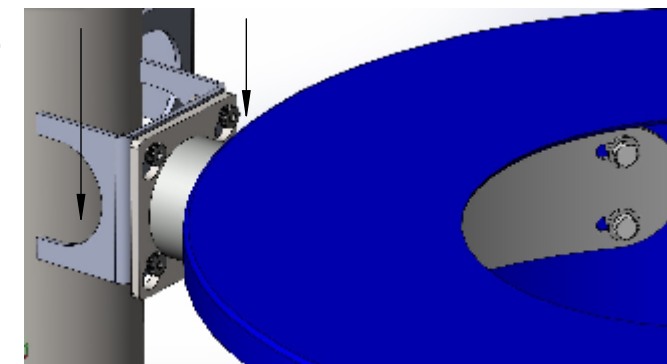

AUTOMAC
Industrial
Vacuum & Air systems

888-628-8682
www.autovacinc.com
sales@autovacinc.com

CLIENT APPROVAL

PROJECT NO.:

DRAWN BY:
ER

SIGNATURE AND DATE:

REV: A

PROJECT TITLE:
**INS - P&S - INSTALL PLASTIC
DETACHABLE TRASH CAN**

PROJECT ADDRESS:

DETACHABLE BRACKET INSTRUCTIONS

BUCKET

- ① INSTALL SHOULDER BOLTS IN POST BRACKET (4 BOLTS PER BRACKET)
- HAND TIGHTEN TO LOCK
(DO NOT USE POWER OR PNEUMATIC TOOLS)
- ONE (1) BRACKET IS NEEDED PER BUCKET

①

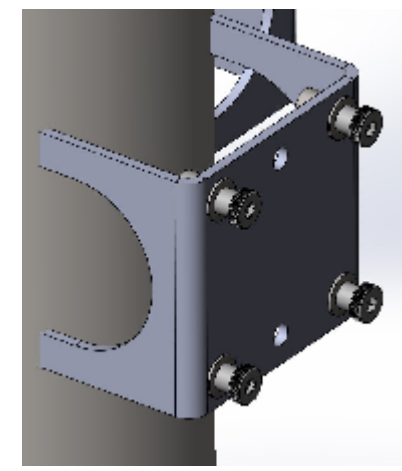
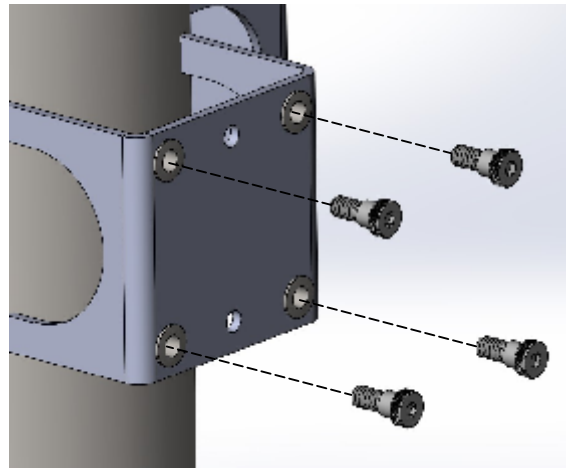

- ② ***OPTIONAL*** FOR TIGHTER FITMENT
- INSTALL SHOULDER BOLTS IN POST BRACKET
(4 BOLTS, 4 FLAT WASHERS PER BRACKET)
- MAKE SURE FLAT WASHERS DO NOT GET FIXED BY THE SHOULDER BOLT
TO THE BRACKET
- HAND TIGHTEN TO LOCK
(DO NOT USE POWER OR PNEUMATIC TOOLS)

②

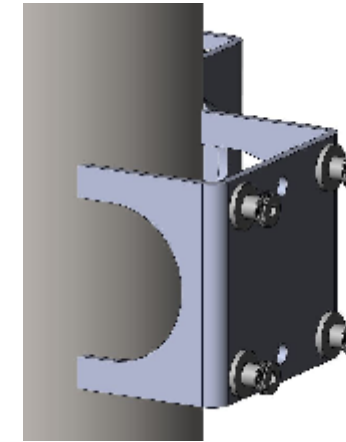
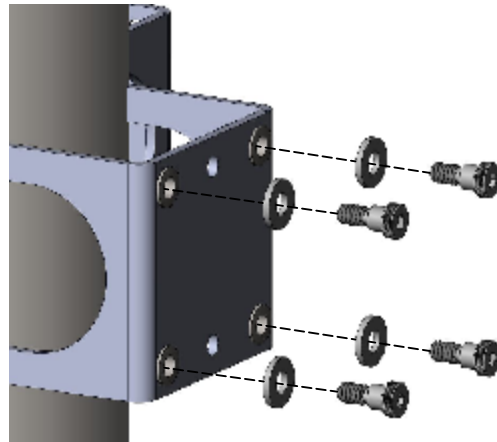

- ③ BOLT BRACKET TO PLASTIC CONTAINER
(4 HEX HEAD BOLTS, 4 FLAT WASHERS PER BRACKET)
- HAND TIGHTEN TO LOCK (DO NOT USE POWER OR PNEUMATIC TOOLS)
- *MAY ALREADY COME INSTALLED FROM FACTORY***

③

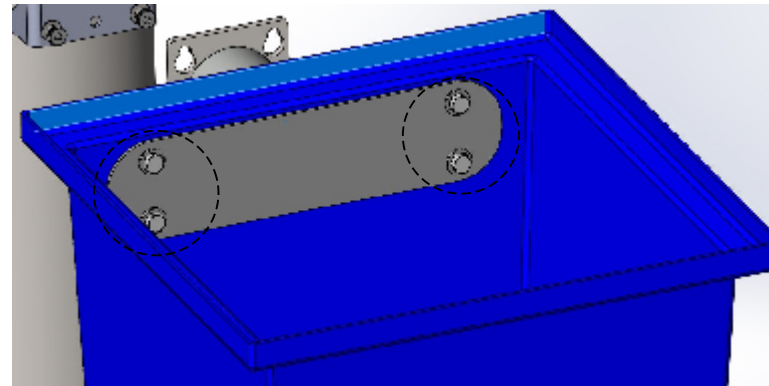

④

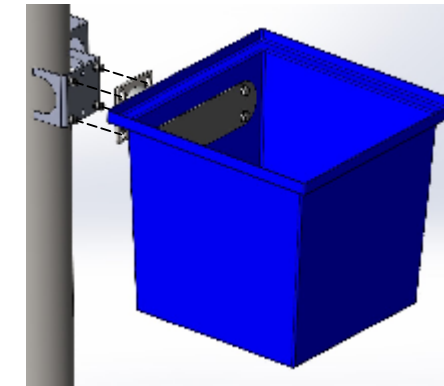

- ④ INSERT BRACKET ONTO SHOULDER BOLTS
- MAKE SURE ALL BOLT HEADS ARE FULLY INSERTED IN BRACKET HOLES

- ⑤ SLIDE BRACKET DOWN TO LOCK IN PLACE
- TO REMOVE OR CLEAN CONTAINERS
SLIDE UP BRACKET TO UNLOCK AND DETACH FROM POST

⑤

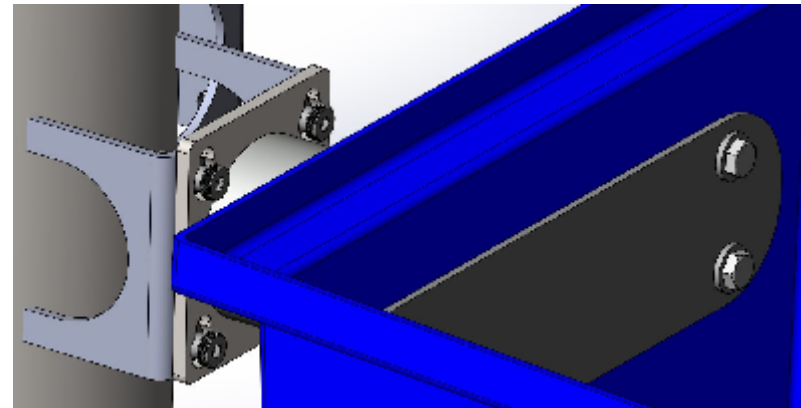

⑤

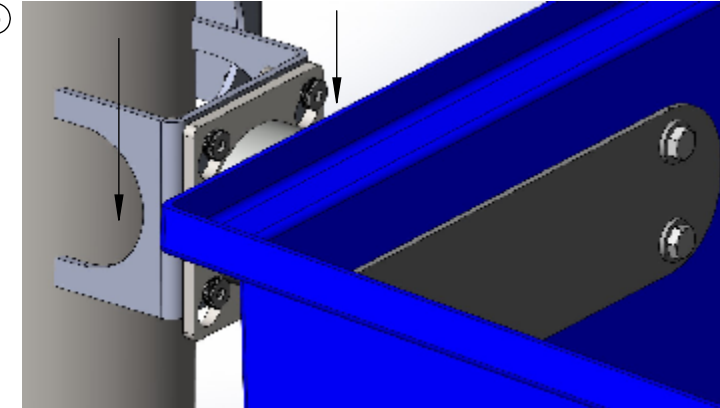

AUTOMAC
Industrial
Vacuum & Air systems

888-628-8682
www.autovacinc.com
sales@autovacinc.com

CLIENT APPROVAL

PROJECT NO.:

SIGNATURE AND DATE:

DRAWN BY:

ER

REV:

A

PROJECT TITLE:
**INS - P&S - INSTALL PLASTIC
DETACHABLE BUCKET**

PROJECT ADDRESS:

INSTALLATION INSTRUCTIONS

EXPRESS NOZZLE

- ① NOZZLE HOLSTER WILL BE INSTALLED USING THE HIGHEST ACCESSORY BRACKET ON THE POST
- ② INSTALL L-BRACKET FACING UP WITH FLANGE PARALLEL TO THE GROUND
HAND TIGHTEN TO LOCK
(DO NOT USE POWER OR PNEUMATIC TOOLS)
- FOUR (4) 1/4" HEX HEAD BOLTS
- FOUR (4) FLAT WASHERS
- ③ HOLSTER CAN BE INSTALLED IN VARIOUS POSITIONS AND ANGLES
- ④ ATTACH EXPRESS NOZZLE HOLSTER TO L-BRACKET
- TWO (2) 1/4" HEX HEAD BOLTS
- TWO (2) FLAT WASHERS

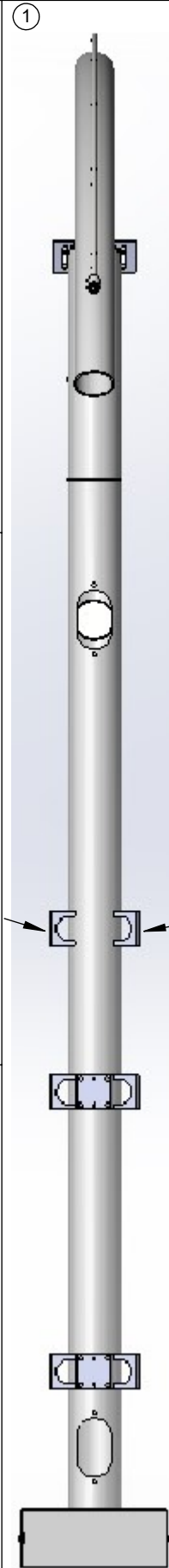

VACUUM NOZZLE HOLSTERS

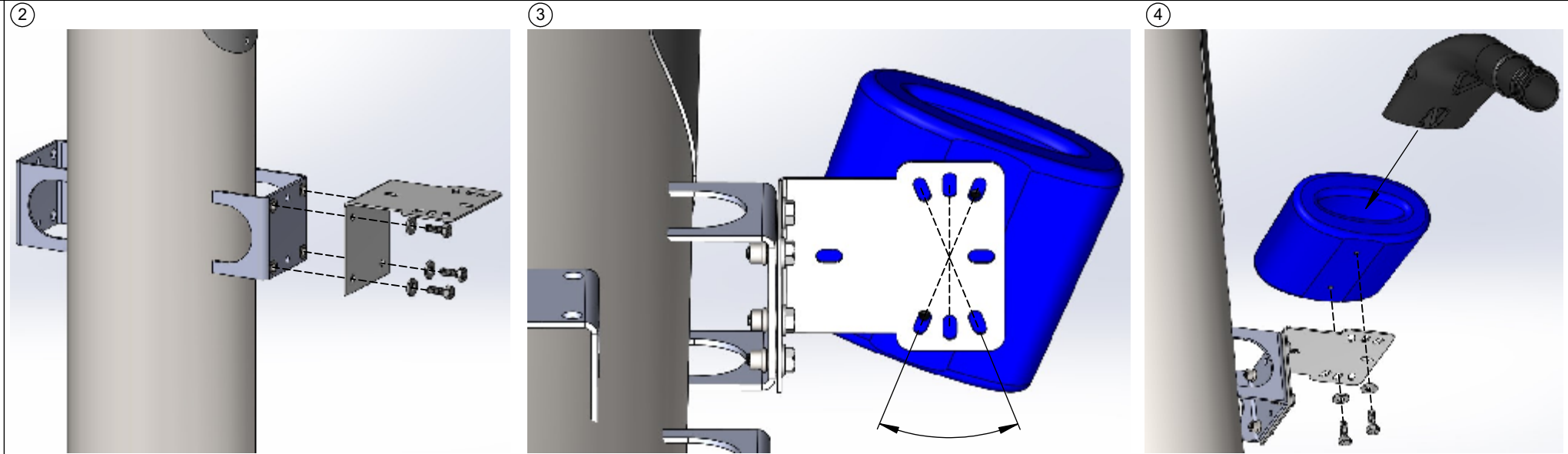

CLAW NOZZLE

- ① NOZZLE HOLSTER WILL BE INSTALLED USING THE HIGHEST ACCESSORY BRACKET ON THE POST
- ⑤ INSTALL L-BRACKET FACING TOWARD THE PARKING SPACE WITH THE FLANGE PERPENDICULAR TO THE GROUND
HAND TIGHTEN TO LOCK
(DO NOT USE POWER OR PNEUMATIC TOOLS)
- FOUR (4) 1/4" HEX HEAD BOLTS
- FOUR (4) FLAT WASHERS PER BRACKET
- ⑥ ATTACH CLAW NOZZLE HOLSTER TO L-BRACKET
- TWO (2) 1/4" HEX HEAD BOLTS
- FOUR (4) FLAT WASHERS
- TWO (4) 1/4" NUTS

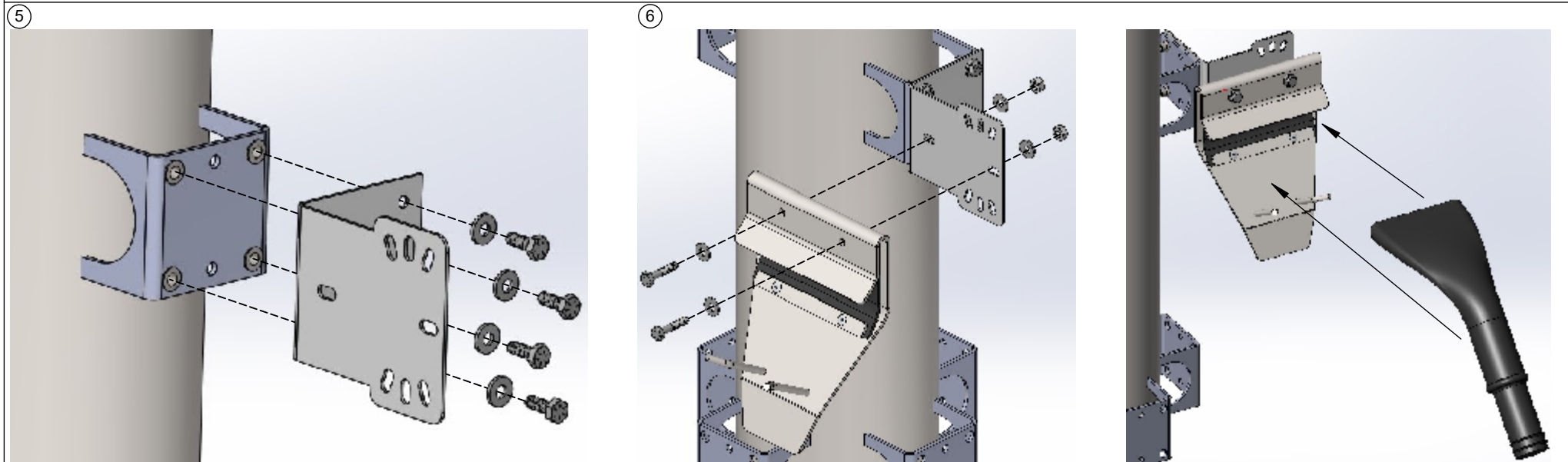

CREVICE NOZZLE

- ① NOZZLE HOLSTER WILL BE INSTALLED USING THE HIGHEST ACCESSORY BRACKET ON THE POST
- ⑦ INSTALL CREVICE NOZZLE HOLSTER DIRECTLY TO THE ACCESSORY BRACKET
ORIENT THE OPEN END AS HIGH AS POSSIBLE
HAND TIGHTEN TO LOCK
(DO NOT USE POWER OR PNEUMATIC TOOLS)
- TWO (2) 1/4" HEX HEAD BOLTS
- TWO (2) FLAT WASHERS PER BRACKET

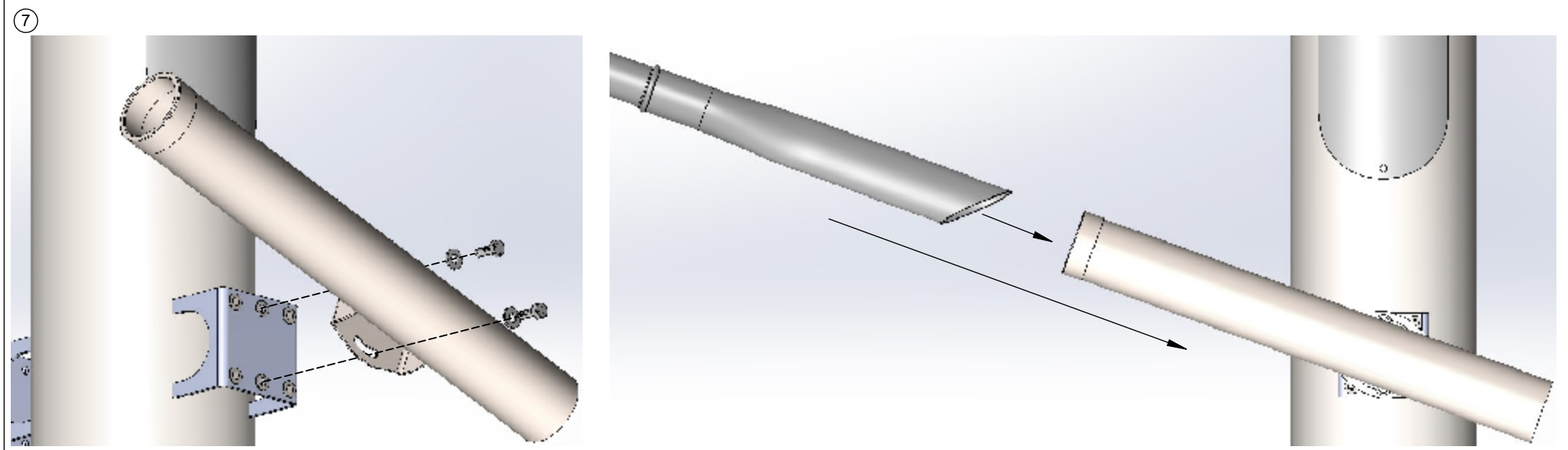

888-628-8682
www.autovacinc.com
sales@autovacinc.com

CLIENT APPROVAL

PROJECT NO.:

SIGNATURE AND DATE:

DRAWN BY:

ER

REV:

A

PROJECT TITLE:
INS - P&S - INSTALL NOZZLE HOLSTERS

PROJECT ADDRESS: