

VACUUM SYSTEMS



Positive Displacement Blower Packages



AVI Vacuum and Air Systems can create a factory direct blower package to your exact specifications from 10 to 100 HP. AVI has been building quality vacuum systems for over 20 years. Our proven results will continue to earn the confidence of our customers worldwide. We offer the highest quality product on the market today. Let our design team build a customized system for years of trouble free performance.

Our package Delivers:

- Pressure to 15 psig
- Vacuum to 16"hg
- 200 – 1500 icfm
- 10 to 100 HP

888-628-8682

email: sales@auto-vac.com • www.auto-vac.com

Positive Displacement Blower Packages

Performance Map

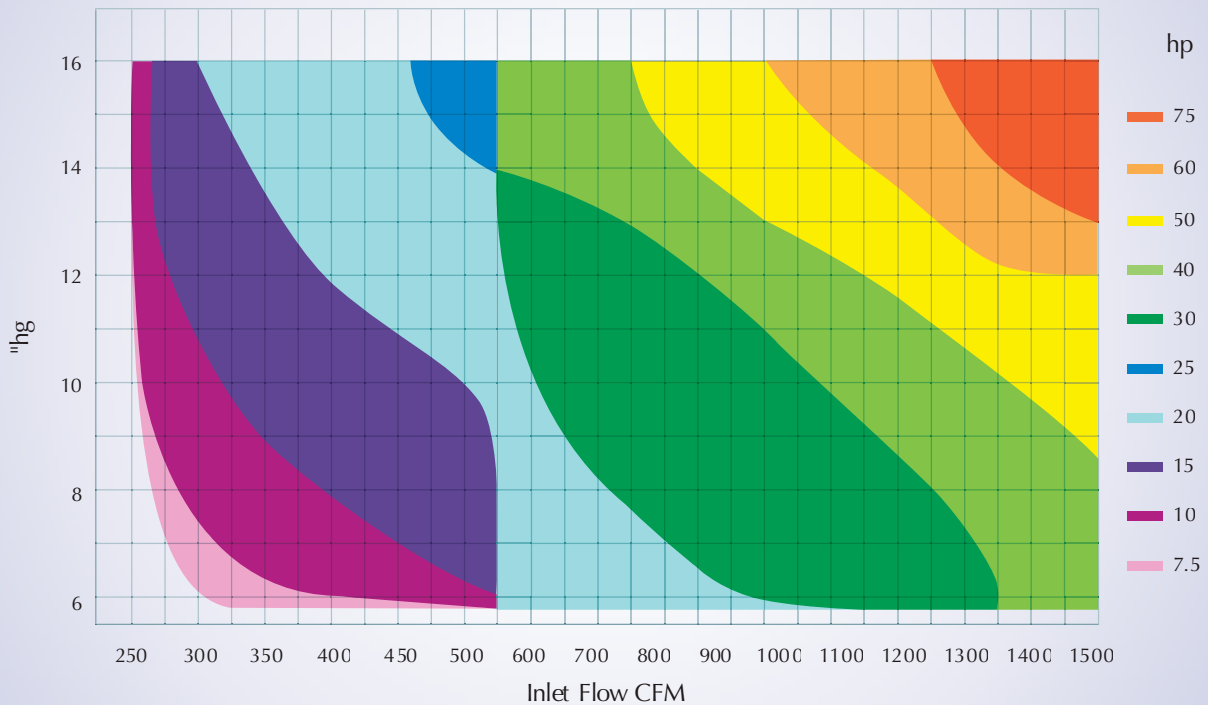

Performance based on inlet air at standard temperature of 68 °F, an ambient pressure of 14.7 psia and 36% relative humidity. For performance at non-standard conditions, contact your authorized AVI representative.

Dimensions

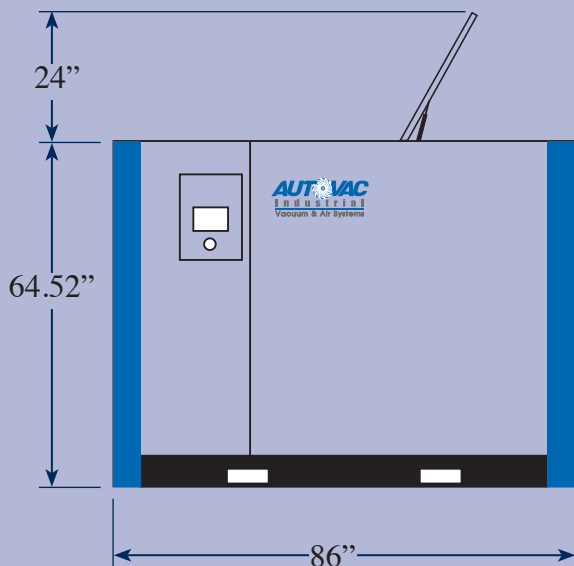

15HP system shown, actual cabinet dimensions vary based on package.

Vacuum IQ

Our positive displacement blower system features Vacuum IQ technology to maximize operational efficiency.

- Dynamic VFD dramatically reduces utility bills
- Operating expenses are minimized through longer service life and lower failure rates
- Intelligent controls allow for remote monitoring of equipment



Choose Your Blower Manufacturer
Choose from Gardner Denver or Tuthill Blowers

Single or twin units
depending on flow and redundancy specifications