

VACUUM SYSTEM

AUTOVAC

Industrial
Vacuum & Air Systems



TOPCAT JR

Compact Industrial Vacuum

So you're tight on space, but you want the durability and performance of a central vacuum system? Meet AutoVac's TOPCAT Jr. – a compact, all-in-one industrial vacuum system. It's perfect for operations with single phase power and limited floor space.

The TOPCAT Jr. provides serious vacuum performance for up to two simultaneous users. Its 5 HP precision engineered Direct Drive motor is stacked directly above the filter separator. Hose hangers are mounted to the unit so there's no need for separate piping or stanchions. The result is outstanding vacuum performance in a small footprint. And the TOPCAT Jr. is easy to install and engineered for years of reliable service with very little maintenance.



888-628-8682

email: sales@auto-vac.com • www.auto-vac.com

TOPCAT Jr.

Single or Three Phase	Model: Standard Performance, 3600 RPM*				
Total Simultaneous Users 15'x1 1/2" Dia. Vac Hose	HP	Vacuum Frame Dimensions	Weight lbs.	Decibels at 10ft.	Order #
1 User	5HP 3600 RPM	27"	350	70	140-0501
2 Users	5HP 3600 RPM	30"	360	70	140-0502

* Please consult your AutoVac sales professional for high altitude applications above 3000'.
Explosion proof motors available.

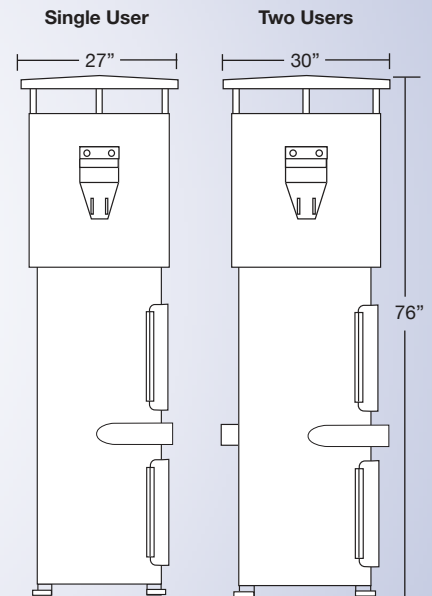
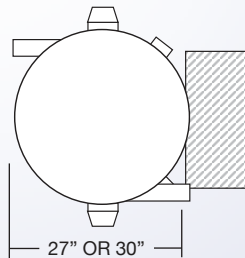

VACUUM SYSTEM LAYOUT AND INFORMATION

ELECTRICAL SECTION



5hp
Up to 2 simultaneous users

Electrical Requirements

Single or Three Phase 60Hz

208/230 volts AC

Please consult your AutoVac professional for the following applications:
Canada – 575 Volt customers
For 50Hz • High altitude above 3,000'

FILTER SECTION



DEBRIS SECTION



*People providing
quality and service,
working to deserve
your business.*

FEATURES AND BENEFITS

CENTRIFUGAL EXHAUSTER

- TOPCAT Jr. ships ready to install, simply connect power and secure bolts
- Compact design fits in tight work areas
- Reliable magnetic starter included
- Constructed of durable 12 gauge steel with epoxy primer and urethane finish
- Aluminum castings allow for fast heat dissipation, extending equipment life
- Muffler included for quiet operation – 70 dB at 10'
- Intake and exhaust openings are directional controlled to accelerate airflow and improve suction
- Precision engineered impellers are dynamically balanced using an electronic balance analyzer

FILTRATION & DEBRIS COLLECTION

- Lip seal gaskets provide positive leak-proof seal on doors
- Extremely durable 8-gallon polypropylene dirt container
- Lockable latches on filter bag area and dirt container
- Filter bags are internally glazed to prevent clogging
- No tools required to remove or replace filter bags
- Durable 15' x 1 1/2" vacuum hose(s) with swivel cuffs