

- (A) These lines carry dirt and debris from Vacuum Cleaning System, one or two lines are required.
- (B) 6" Vacuum Producer exhaust air. Pipe to atmosphere 20 ft. max. with metallic pipe no smaller than 4".
- (C) 6" Vacuum Producer inlet air and filter separator vacuum supply line.
- (D) Not used
- (E) Foot pad leg support, 3 locations typical.
- (F) Industrial duty 4 bearing, coupled vacuum producer.
- (G) Support pipe every 10 ft. minimum with an approved support hanger system. Never allow pipe to sag. Install hangers as needed. Sway brace as required.
- (H) Optional Equipment: Electrical connection required for disconnect switch, magnetic starter or Vacuum IQ to Vacuum Producer per local code. Installation location to vary.
- (I) Filter Separator Model # SF101Z.
- (J) 6" diameter pipe carries dirt from system. See pipe system drawings.
- (K) Foot pad leg support, 3 locations typical. Do not bolt down firm, leave lock nut on stud 1/2" above mounting plate.
- (L) Transducer cable from Separator to Vacuum IQ via conduit (supplied by others).
- (M) Motor control cable from Vacuum Producer to Vacuum IQ via conduit (supplied by others).
- (N) Vacuum I.Q (Optional)
- (P) Disconnect Switch

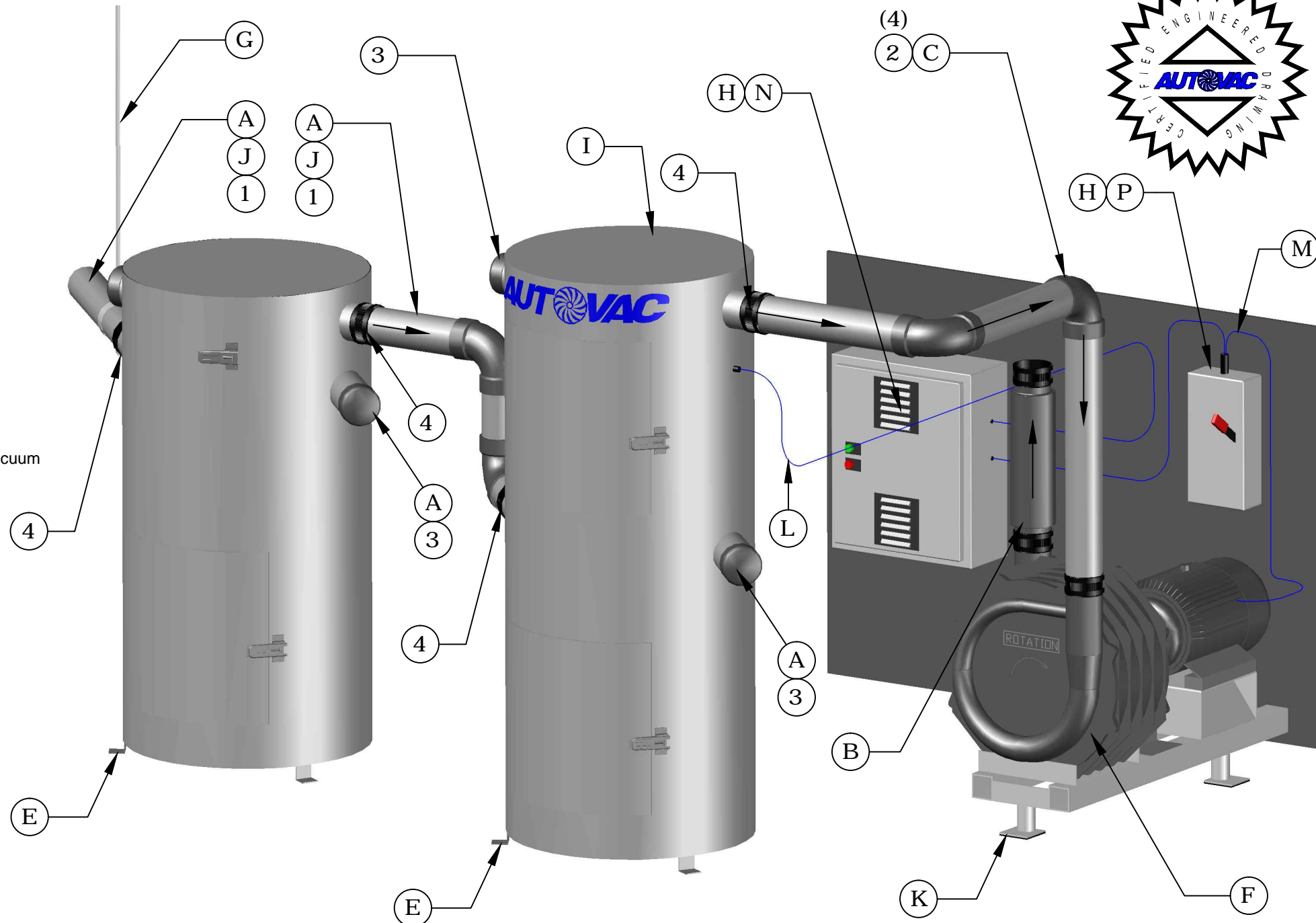

AUTOVAC
Industrial
Vacuum & Air Systems

| | |
|------------------|--|
| APPROVED BY: | |
| DATE: | |
| DESCRIPTION: | |
| DRAWN BY: | |
| REVISION NUMBER: | |

6" SINGLE VACUUM PRODUCER, FILTER SEPARATOR & PRIMARY SEPARATOR EQUIPMENT HOOK-UP KIT - ABS

CHECKED BY: MFG. APPROVAL SHEET NO. XXX
 DATE: 10/25/2012
 SALES PERSON: FINAL: ST
 DATE: 10/25/2012
 ST

1 OF 1

EQUIPMENT HOOK-UP PARTS LIST

| NO. | DESCRIPTION | PART NO. | MFR. | QTY. |
|-----|-----------------------------|-----------|---------|------|
| 1 | 6" ABS PIPE | C521-0004 | AUTOVAC | 30' |
| 2 | 6" ABS LONG SWEEP 90° ELBOW | C526-0204 | AUTOVAC | 7 |
| 3 | 6" ABS CAP | C529-0004 | AUTOVAC | 3 |
| 4 | 6" NO-HUB | C591-0004 | AUTOVAC | 3 |

All pipe and fittings will be shipped ABS material DWV (drain, waste & vent) style fittings. All fittings will be long sweep directional flow. Partial reproduction of material inside borders is not authorized. copyright 2011, AVI Car Care, LLC

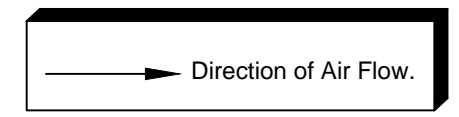

6" SINGLE VACUUM PRODUCER, FILTER SEPARATOR & PRIMARY SEPARATOR EQUIPMENT HOOK-UP KIT ABS PIPE

X209-6 **AUTOVAC**