

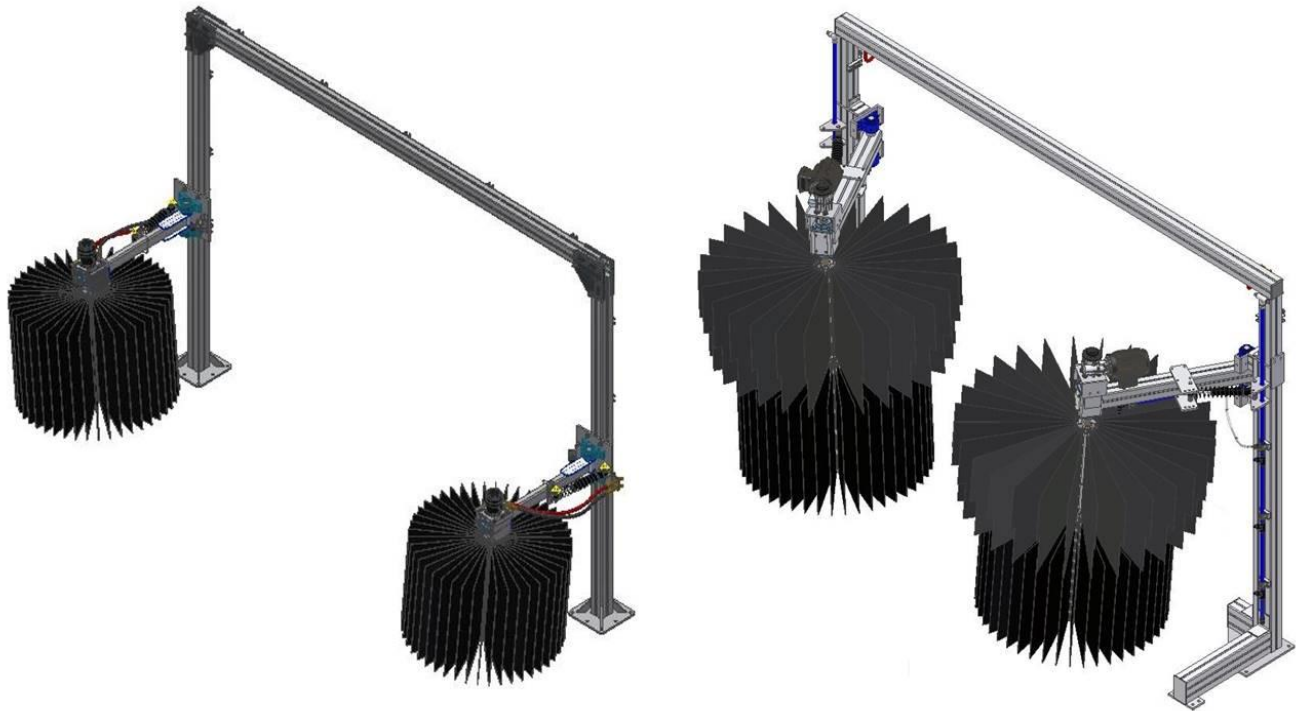

Top Mount Side Washer



Owner's Manual

Sonny's Enterprises, Inc.
5605 Hiatus Road
Tamarac, Florida 33321

Table of Contents

<u>SAFETY REQUIREMENTS AND WARNINGS</u>	3 - 4
<u>Introduction</u>	5
<u>Product Features</u>	6
<u>Product Specifications</u>	7
<u>Hub Configuration</u>	8
<u>Specifications</u>	8
<u>UTILITIES REQUIREMENTS</u>	9 - 10
<u>INSTALLATION</u>	11 - 23
<u>Dimensions for 18in to 35in Brushes</u>	13
<u>Dimensions for 50in Brushes</u>	14
<u>Dimensions for 63in Brushes</u>	14
<u>Adjustments and Testing</u>	24
<u>GENERAL OPERATION</u>	25
<u>Do’s and Don’ts</u>	26
<u>MAINTENANCE</u>	27 - 28
<u>Replacement Parts</u>	29 - 36
<u>Customer Service</u>	37
<u>Warranty</u>	38

SAFETY REQUIREMENTS AND WARNINGS

1. All employees must be thoroughly trained in safe operation and standard maintenance practices. All employees must review this entire manual monthly.
2. Do not enter the wash tunnel when the equipment is operating. Death or dismemberment may occur.
3. Do not wear loose fitting clothing or jewelry around moving equipment. Do not allow any part of your body or other objects (including ladders, hoses or tools) to come in contact with moving equipment. Entanglement may result causing death or dismemberment.
4. Do not leave a ladder or any other items such as wash down hoses or tools in the wash tunnel while equipment is running. Vehicle damage and injury, including death, can occur.
5. Always exercise caution when walking (never run) through the wash tunnel as there may be slippery conditions. Be careful so you do not bump into or trip over equipment.
6. Only those employees specifically instructed and trained by the location management are permitted to enter the wash tunnel to perform inspections or maintenance. At least two qualified maintenance people must be present when performing equipment repairs or preventive maintenance.
7. Do not perform any maintenance or work on equipment unless you first perform Lock-Out Safety Precautions. All electrically powered equipment must have manually operated disconnects capable of being locked in the "OFF" position. Equipment that has been "locked out" for any reason must be restarted only by the person who performed the "lock out" operation.
8. When working on any equipment that is higher than your shoulders, always use a fiberglass ladder that is in good condition.
9. Do not attempt to repair or adjust any pressurized liquid or pneumatic part, hose, pipe or fitting while that equipment is in operation.
10. Electrical connections and repairs must be performed by a Licensed Electrician Only.
11. Emergency "STOP" buttons must be well marked and their location and proper use reviewed with all personnel. Any activated "STOP" button must be reset only by the person who activated it. Clear the wash tunnel of any people, ladders, hoses, tools and other loose items before restarting the equipment. An audible device must sound to warn people that the equipment is starting.

SAFETY REQUIREMENTS AND WARNINGS

12. Do not operate any piece of equipment that requires safety covers with those covers removed or improperly installed. Do not operate any piece of equipment if any component of that piece is suspected to be defective or malfunctioning.
13. Store all cleaning and washing solutions and oils in a well-ventilated area. Clean up fluid spills immediately to prevent hazardous safety conditions. Be certain to follow all safety procedures on SDS Sheets for each chemical product used.
14. All hydraulic and electric systems in the wash tunnel equipped with a torque relief or overload should be checked and set at the minimum amount that will allow for proper functionality under normal washing conditions.
15. No unauthorized people should ever be permitted in the wash tunnel or near the equipment at any time.

* * *

!! CAUTION !!

When a piece of equipment must be in operation during inspection or maintenance, one qualified technician must stay at the power disconnect switch while another qualified technician performs the inspection or maintenance.

Introduction

This Manual contains information that is vital to the successful installation, operation and maintenance of your Sonny's vehicle washing equipment.

Please read, and understand, the full contents of this manual before installation and operation of the equipment. Keep this booklet in a location where it may be used for ongoing reference.

Should you have any questions on the operation or servicing of this equipment please contact:

**TECHNICAL SERVICES DEPT.
SONNY'S ENTERPRISES INC.
5605 Hiatus Road
TAMARAC, FLORIDA 33321**

TELEPHONE: 800-327-8723 FAX: 800-495-4049

THANK YOU FOR YOUR CONFIDENCE IN SONNY'S!



Product Features

- Sonny's **Top Mount Side Washers** spin against vehicle travel, which is the opposite direction of our wrap around washers. This allows the cloth to get into different areas to provide thorough cleaning.
- **Top motor design** provides easy access for preventive maintenance.
- **Multi-Tiered hub** delivers optimal penetration and movement, permitting a single side washer to remove heavy rocker panel dirt while delivering deep gentle cleaning to contoured sides and mirror backs.
- Adjustable **shock absorber control** for accurate pressure and material penetration.
- Vehicle contour brush tracking.
- Frame and legs constructed from **aluminum** or **stainless steel**.
- Optional **Powder Coating**.
- **Brush Material**



Hush Brush™ Foam Series

Hush Brush™ design reduces noise and allows better contact with the durability of NEOGLIDE® Foam Wash Material.

Product Specifications

- Available in two cleaning configurations with different heights depending on brush length:

- Small brush configuration:
 - 18", 21", 28" or 35"
 - **NeoGlide Hush** material
- Large brush configuration:
 - 50" or 63"
 - **NeoGlide Hush** material



- Double roller bearings
- Requires 1/2" city water connection
- Available with **Electric** or **Hydraulic motor**
 - Available electric drive motors in low voltage and high voltage
 - Hydraulic brush drive motors for **Small Brush** configuration use **3GPM @ 800PSI**
 - Hydraulic brush drive motors for **Large Brush** configuration use **6GPM @ 800PSI**

Hub Configuration

Side Washer	SF 18”	SF 21”	SF 28”	SF 35”	SF 50”	SF 63”
Top Driver Hub	2.5” (extrusion)				6”	
Top Passenger Hub	2.5” (extrusion)				6”	
Bottom Driver Hub	2.5” (extrusion)				10”	
Bottom Passenger Hub	2.5” (extrusion)				10”	
Driver Side Slots	44	32	44	16	28 top / 36 bottom	
Pass Side Slots	44	32	44	16	28 top / 36 bottom	

Specifications

Side Washer	SF 18”	SF 21”	SF 28”	SF 35”	SF 50”	SF 63”
Footprint Length	74”					
Footprint Width	144”					
Height	142”					
Vehicle Clearance	90” (2.286m)					
Water Inlet	1/2” (12.7mm)					
Hydraulic Option	3GPM @ 800PSI per motor				6GPM @ 800PSI per motor	
Electric Option	3-Phase 208-460V per motor					

UTILITIES REQUIREMENTS

UTILITIES INTERCONNECTION AND THE MATERIALS REQUIRED FOR INTERCONNECTION TO SONNY'S EQUIPMENT ARE THE RESPONSIBILITY OF THE CUSTOMER.
PERFORM ALL TRADES WORK TO ALL APPLICABLE LOCAL AND NATIONAL CODES.

Water

- The Customer's Plumber is to provide and install a ½" city water line @**60PSI** (nominal) to the solenoid valve on the chemical distribution system for the Washer.

Hydraulic

- Hydraulic brush drive motors for **Small Brush** configuration use **3GPM @ 800PSI**
- Hydraulic brush drive motors for **Large Brush** configuration use **6GPM @ 800PSI**

Electrical

- The Customer's Electrician is to provide and install single phase power from the (**24 or 110 VAC** as determined at time of order) from the Customer's Controller system to the liquid solenoid valve for the brush spray bars and, if required, the motor starter coil for the hydraulic power pack feeding the two brushes and any pump motor for the chemical distribution system.
- Where applicable the Customer's Electrician is to provide materials and install **208VAC or 230VAC or 460VAC, 3-phase, 60Hz** power to the electric motor on the hydraulic power pack or VFD panel from a properly sized three pole circuit breaker and motor starter with three thermal overloads.
- Where applicable, the Customer's Electrician is to provide materials and install **190~230 VAC or 380~460VAC, 3-phase, 60Hz** power to the electric motor.

UTILITIES REQUIREMENTS

Optional Retract Kit Requirements

Electrical

- The Customer's Electrician is to provide and install single phase power from the remote push-button station through the tunnel equipment programmer to the supplied air solenoid valve on the Air Distribution Manifold for retract of both washers upon selective signal (see **Figure #4** in Dimensions Section).

Compressed Air

- The Customer's Plumber is to provide and install a ½" compressed air line from the Air Compressor to the Air Distribution Manifold for the Retract functions.

QUESTIONS?

CALL

TECHNICAL SERVICES DEPT.

SONNY'S ENTERPRISES INC.

TAMARAC, FLORIDA

TELEPHONE: 800-327-8723 FAX: 800-495-4049

INSTALLATION

Tools

1. Safety Glasses
2. ½" Drive Ratchet Set
3. Standard Combo Wrenches
4. Tape Measure
5. Permanent Marker
6. 4' Level
7. Electric Impact Wrench
8. 5' Pry Bar
9. 1" Hammer Drill
10. Sledgehammer

Consumables

1. Teflon Paste
2. Teflon Tape

Work Force

One (1) Person

Time (assuming no problems)

3.00 – 4.00 hours

Installation Steps

1. Determine where the Washer Frame is to be installed. Refer to tunnel layout diagram.
2. Sweep any debris from where the Washer will stand.

Note: Ensure the Washer Frame is correctly located before installing any lag bolts. Before lagging the frame into position, have a second person double check all measurements against your tunnel equipment layout drawings to ensure all measurements were performed correctly.

3. Bring the washer frame into the building using the lift-a-ma-jig. Do not cut the brush arms free.
4. Place the frame **46"** from the inside of the passenger guide rail and the correct distance from the entrance for your tunnel layout.
5. Square the washer frame to the conveyor. Plumb the legs and level the hanger arms. Shim the base as needed.
6. Lag one corner of the driver's side base and recheck all measurements. Once confirmed, lag the opposite corner on the passenger's side then finish lagging the brush in place.
7. Check that the shock on each brush hanger does not "bottom out" in their fully extended positions. If this occurs, move the shock mounting position to a different hole on the mounting bracket to prevent a fully extended condition.

INSTALLATION

Note: The Sonny's supplied BLACK high-pressure hose on the washer unit is for the hydraulic **PRESSURE** connection and the ORANGE OR RED high-pressure hose on the washer unit is for the hydraulic **RETURN** connection.

8. Run and connect a ½" **PRESSURE** line from the Hydraulic Power Pack to the ½" male pipe thread fitting on the **BLACK** high-pressure hose on the leg of the Washer.
9. Run and connect the ½" **RETURN** line to the Hydraulic Power Pack to the ½" male pipe thread fitting on the **ORANGE OR RED** high-pressure hose on the leg of the Washer.
10. Run and connect the chemical lines from the Chemical Distribution Manifold to the chemical line on the Wrap frame for the application nozzles.
11. Rotation of the Brushes is against vehicle travel. As viewed from the top of each Brush the **DRIVER** side turns **CLOCKWISE** and the **PASSENGER** side turns **COUNTERCLOCKWISE**.
12. Run and connect the air lines from the Air Distribution Manifold to the air cylinder for each retract (see **Figure #4** in the **Dimensions Section**).
13. Install cloth on the Brush Cores according to the type of material being used (see **Insert Patterns** in the **Dimensions Section**).

INSTALLATION

Dimensions for 18in to 35in Brushes

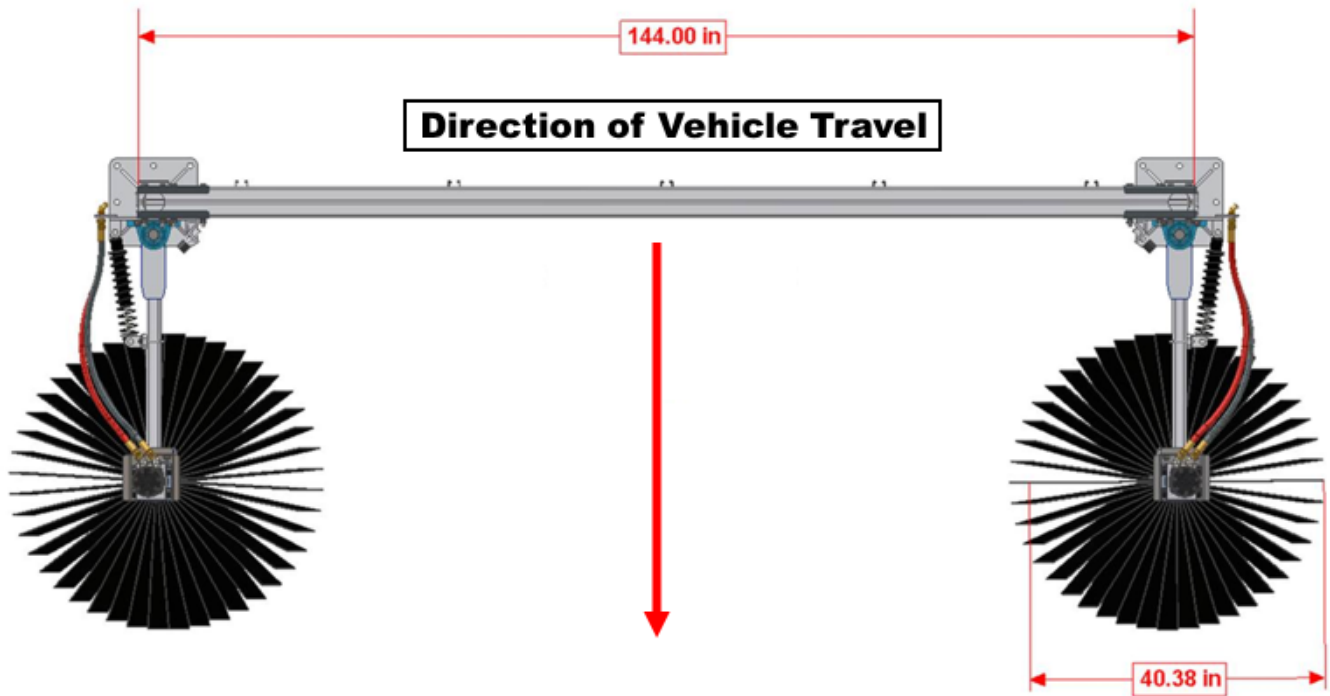

INSTALLATION

Dimensions for 50in Brushes

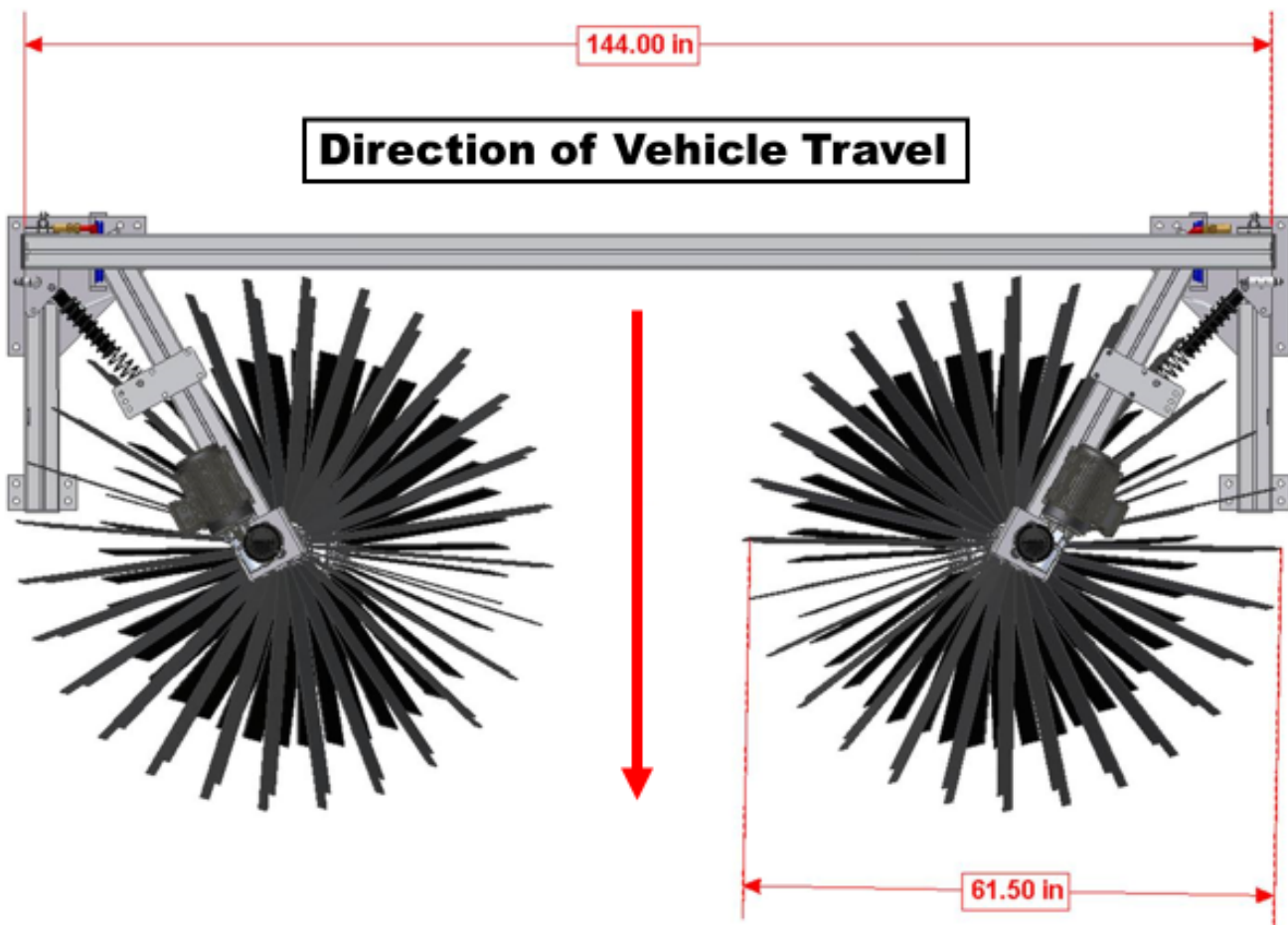

INSTALLATION

Dimensions for 63in Brushes

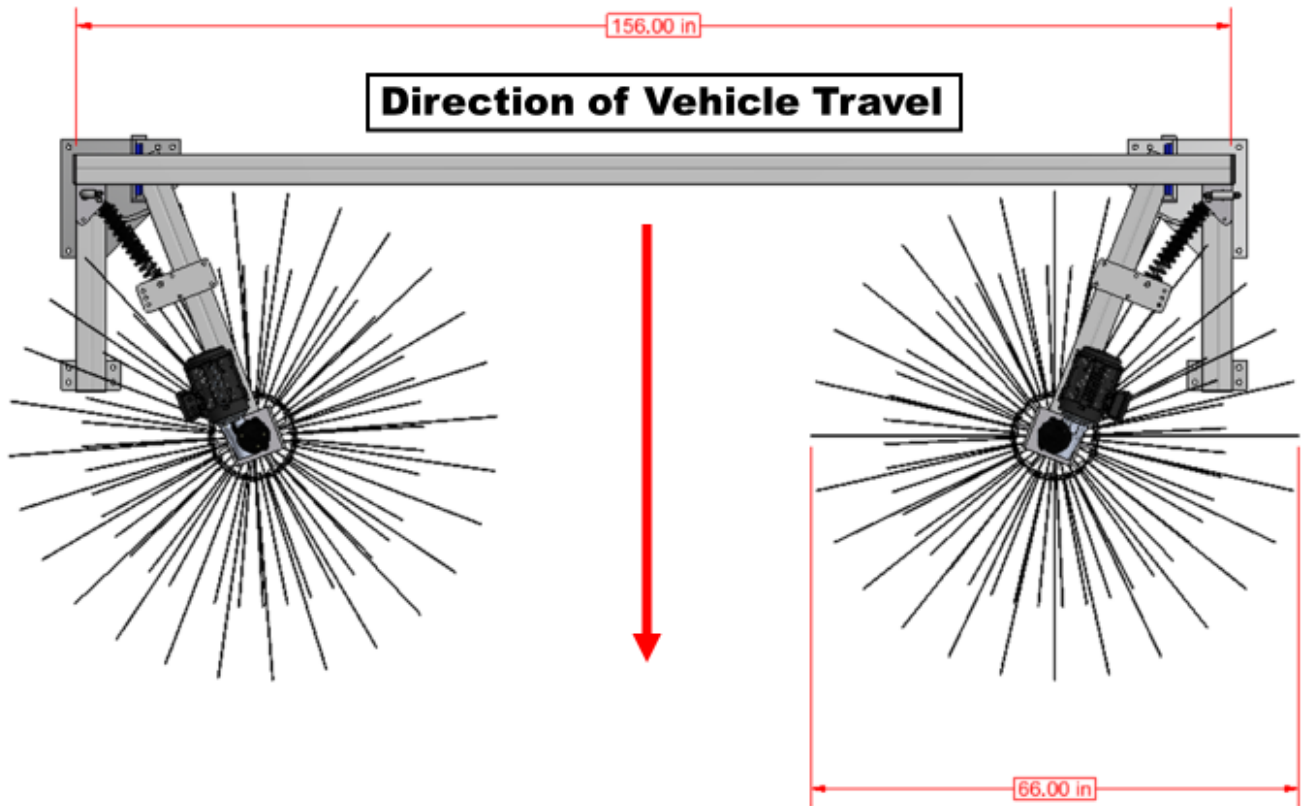

INSTALLATION

Figure #1

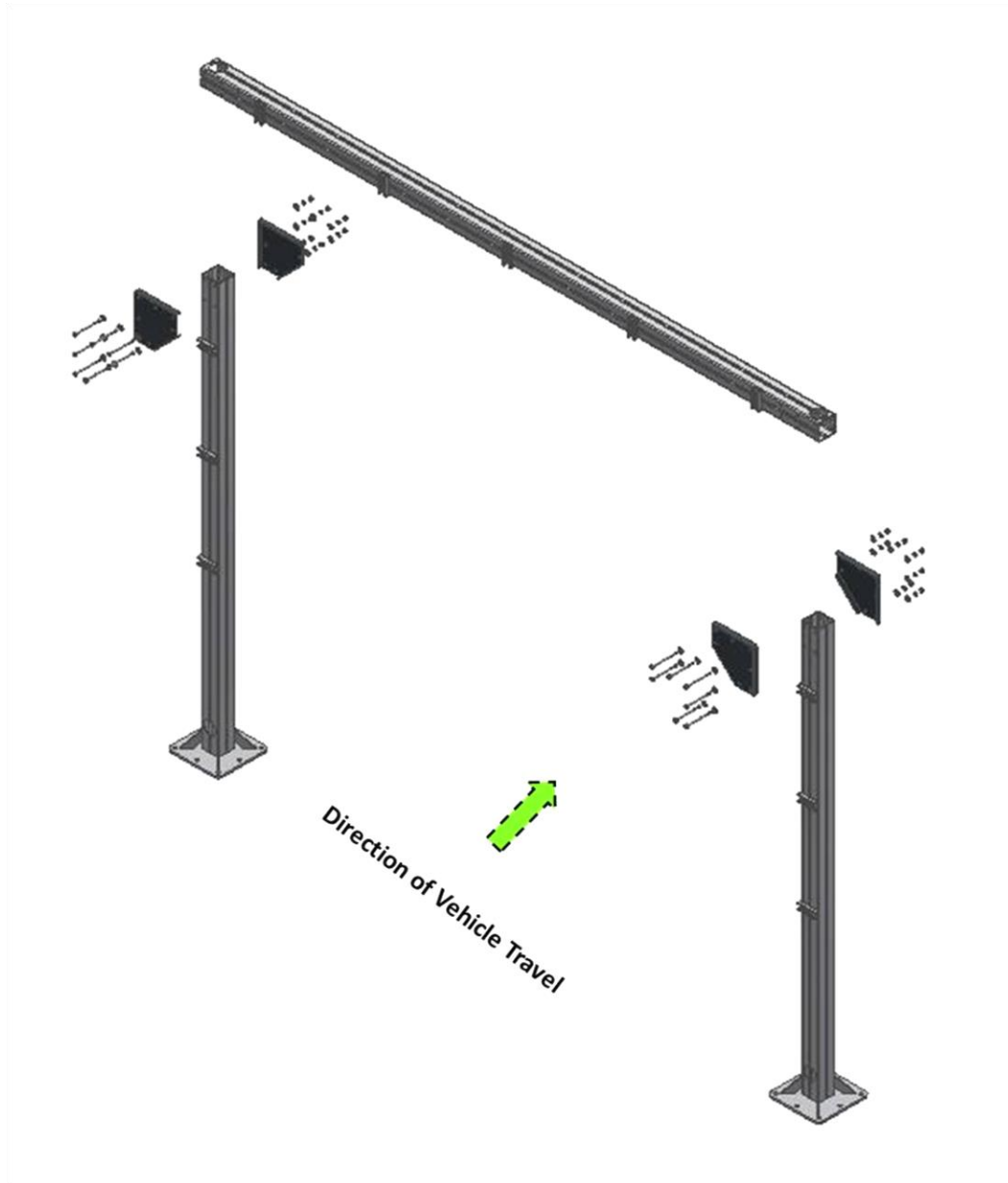

INSTALLATION

Figure #2

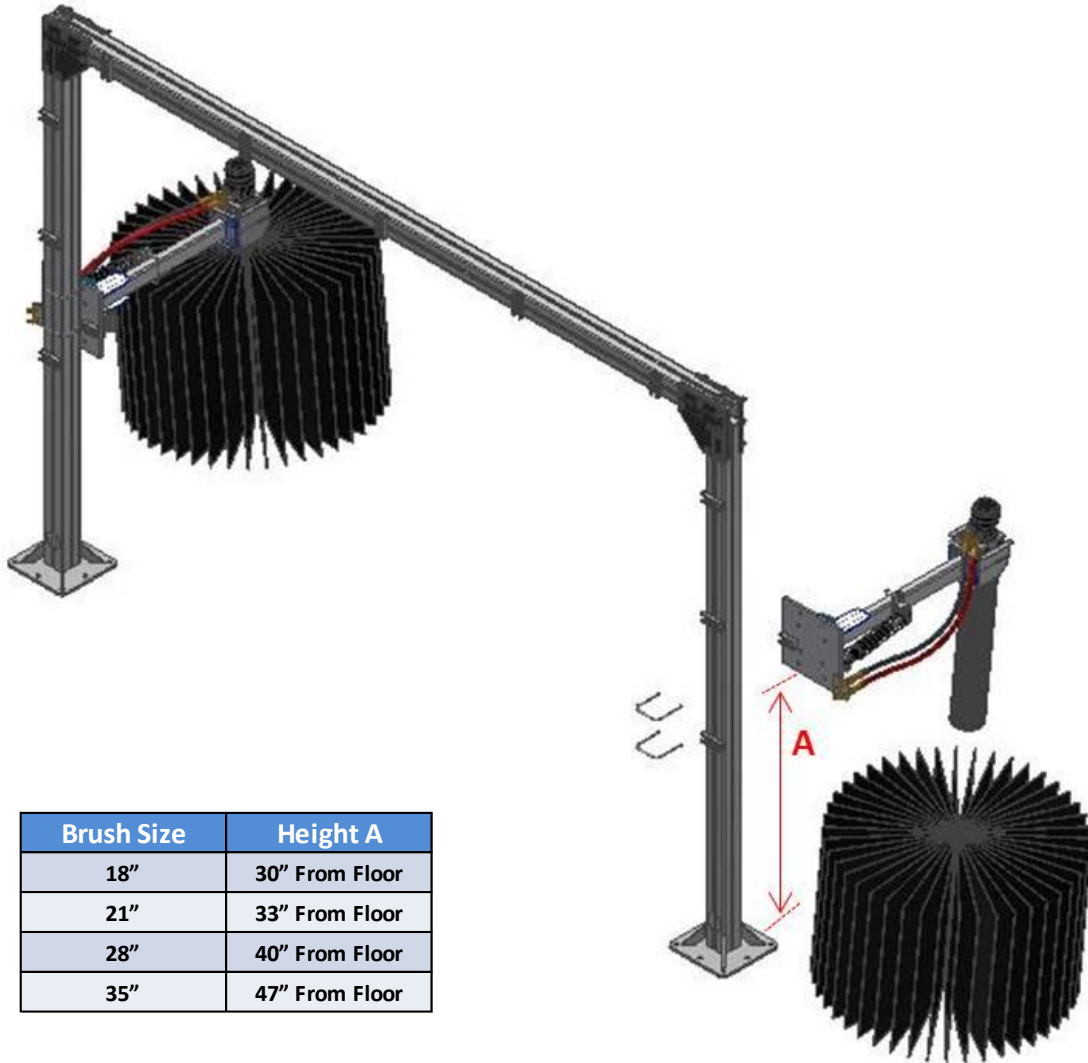

INSTALLATION

Figure #3

SONNY’S MODEL #SF68 FLEX SHAFT WRAPAROUND WASHERS

PROGRAMMABLE EXTEND INTERCONNECTION DIAGRAM

TYPICAL EACH CYLINDER

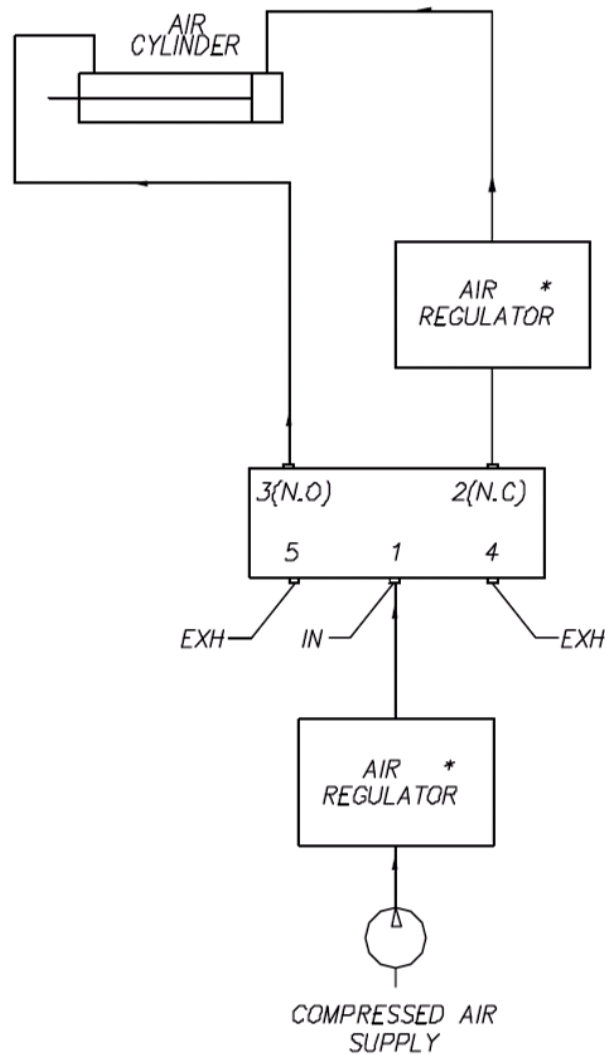

INSTALLATION

Figure #4

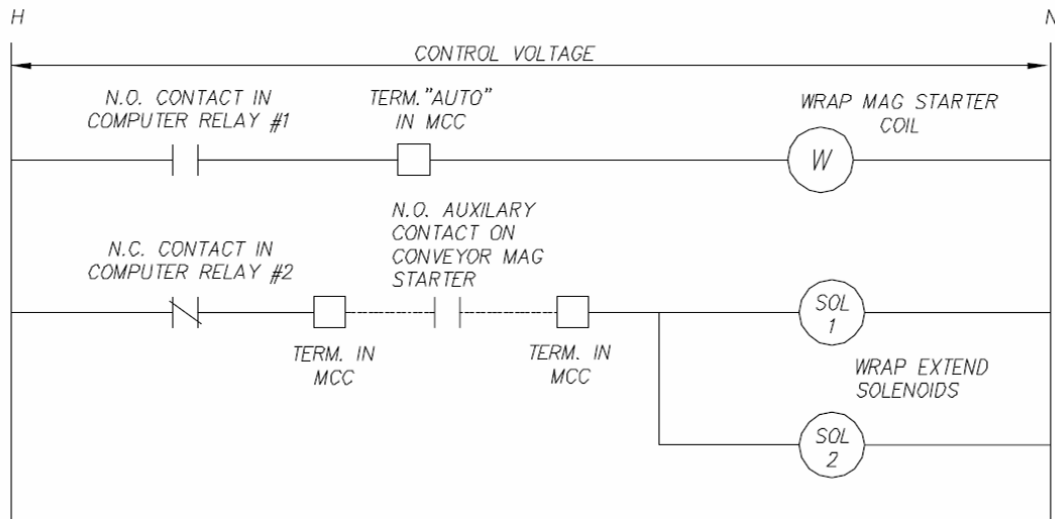
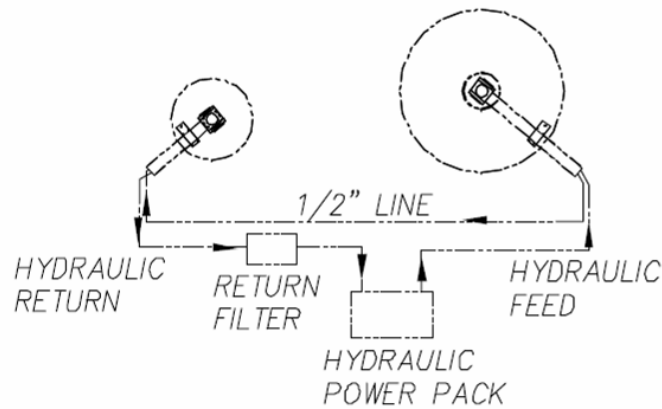

Figure #5

SONNY'S MODEL #SF50 & SFB50
"SUV" SIDE WASHERS

HYDRAULIC INTERCONNECTION



INSTALLATION

18in to 35in Size Brush – Exploded View

The top beam is secured to the legs with aluminum plates. Sonny's recommends using an **anti-seize lubricant** on the plate bolts.

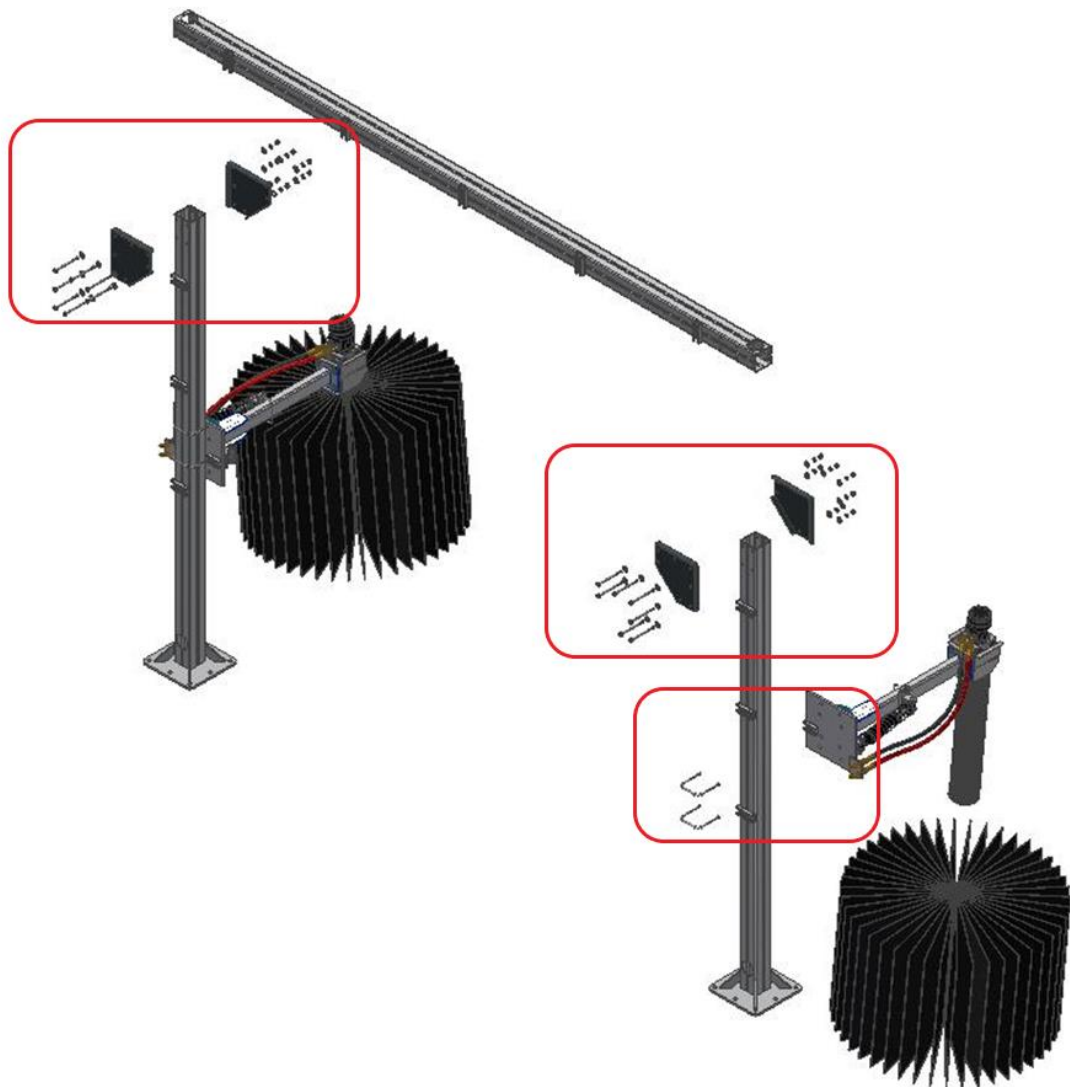

Threaded **U-Bolts** are used with a washer and nut to attach the arms.

INSTALLATION

50in and 63in Size Brush – Exploded View

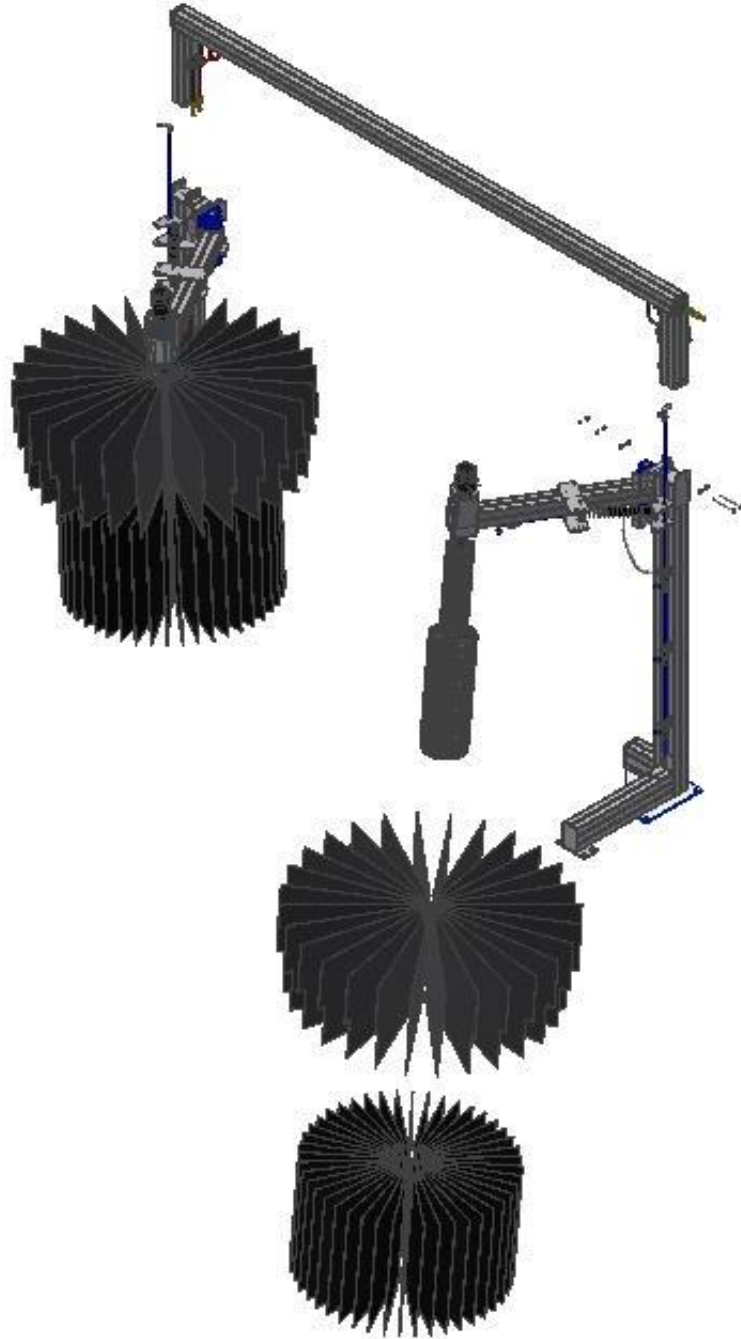

INSTALLATION

Insert Patterns 28 Slot Hub 6" Diameter

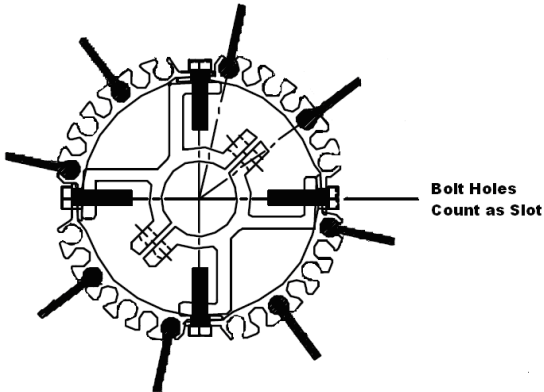

8 Position Material

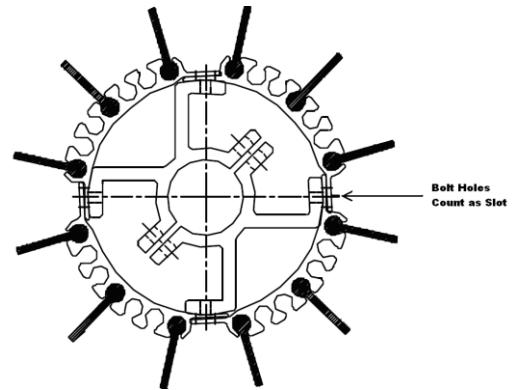

12 Position Material

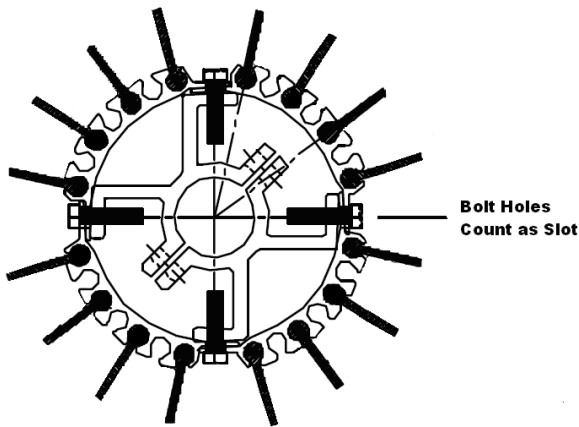

16 Position Material

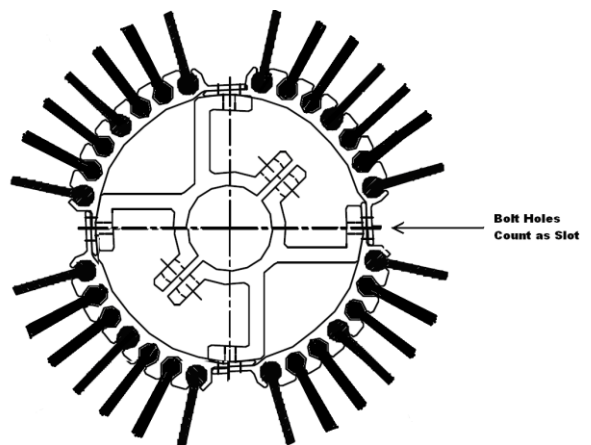

28 Position Material

INSTALLATION

Insert Patterns 44 Slot Hub 12" Diameter

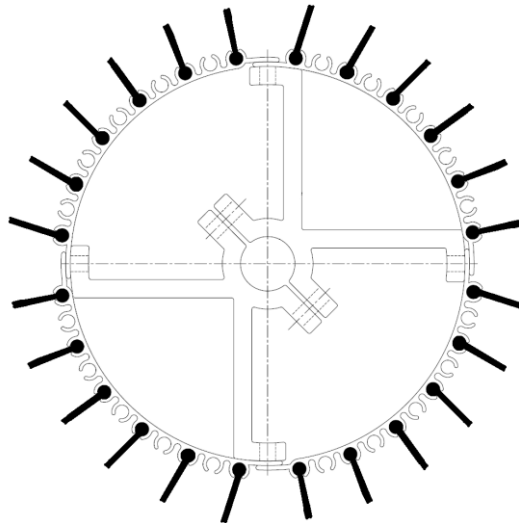

24 Position Material

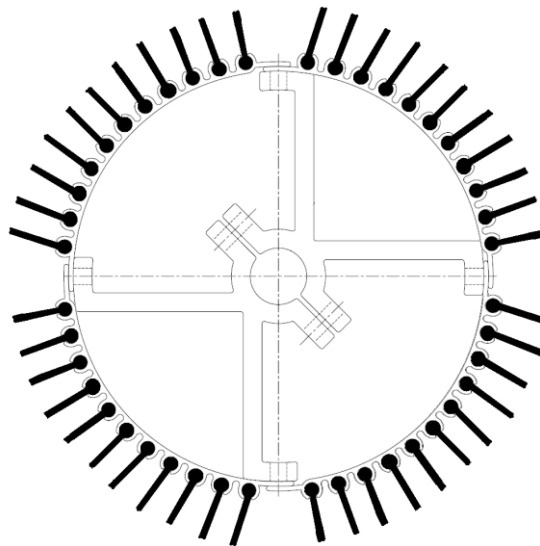

44 Position Material

Adjustments and Testing

Adjust the Cleaning Pressure of the Washer

To adjust the pressure applied to the vehicle the mounting position and the spring position of the shocks can be changed. Cloth penetration should be about **3 to 4 inches**.

Speed and Torque Adjustment (where applicable)

1. Hydraulic
 - a. The speed can be adjusted on the flow control for the power pack.
 - b. To increase the speed, move the handle on the flow control closer to the number **10**.
 - c. To decrease the speed, move the handle on the flow control closer to the number **1**.
 - d. The torque must be set prior to operation and should be set between **600 and 900 PSI**. For information on how to set the torque please refer to the Hydraulic Power Pack Manual.
2. Electric
 - a. The speed can be adjusted on the Variable Frequency Drive (VFD).
 - b. To increase the speed, adjust the Hertz on the VFD to a higher number.
 - c. To decrease the speed, adjust the Hertz on the VFD to a lower number.
 - d. The Overload on the Motor Starter protector(s) must be set at the lowest level to allow for operation. Adjust the amps in accordance with motor(s) name plate.
 - e. The following table shows the idea wrap speed, based on your chain speed:

Chain Speed	Wrap Speed	Top Speed
50-70CPH	70-75RPM	75-85
70-80CPH	80-85RPM	75-85
80-90CPH	85-90RPM	75-85
90-125CPH	90-95RPM	85-95

GENERAL OPERATION

Side Washer Operation

Brush rotation starts and stops with a signal from the Customer supplied Controller system to the Customer's hydraulic power pack which drives the hydraulic motors on the brushes, or if applicable, from the controller system to the electric motors. This Controller Start-Stop signal should also control soap solution delivery to the spray bar on each brush.

BE CERTAIN THAT THE BRUSHES ROTATE AGAINST VEHICLE TRAVEL.

With the brushes rotating (against the direction of vehicle travel and at proper RPM) the vehicle's front fender contacts the washers as they travel across the side of the vehicle, maintaining steady contact while cleaning the sides of the vehicle.

Proper **cloth penetration** on flat vehicle surfaces should be **3 to 4 inches**. As the side washers gear around corners, such as fenders, cloth penetration may be greater, but not deeper than half the distance to the aluminum brush core.

Optional Retract Operation

When selected by the Operator's remote Programmer push button station, the side washer brushes will retract from the center of the wash tunnel toward the tunnel outer walls. This can be done individually if one solenoid is used for each arm.

This is accomplished, when the push button is pressed, by completing an electrical circuit through the equipment Programmer to pass single-phase power at the preset pulse count of the Programmer to the retract the air solenoid valve. The air solenoid valve now opens and allows compressed air to pass through to the rod end port of each air cylinder, causing the brush hangers to retract.

Do's and Don'ts

DO 

- Use an **anti-seize lubricant** on the plate bolts.

DON'T 

MAINTENANCE

DAILY

1. Check all hydraulic, air and chemical lines and fittings for leaks. Repair, or replace, as needed.
2. Check electrical fittings and connections; make sure they are sealed tight.
3. Check both brush units for proper operation and retract operation, listening for any unusual noises from the equipment.
4. Inspect brush cloth for cuts, grease, or oil. Remove and repair, or replace, any cloth panel if any of these conditions are found.
5. Check for proper chemical solution delivery.

WEEKLY

1. Grease the brush shaft four bolt flange bearings. These are **rotational bearings**, so they should be greased **every week**. Use **two pumps of grease** for each rotational bearing. Do not allow grease to come in contact with brush cloth (wipe the grease fittings clean after greasing).

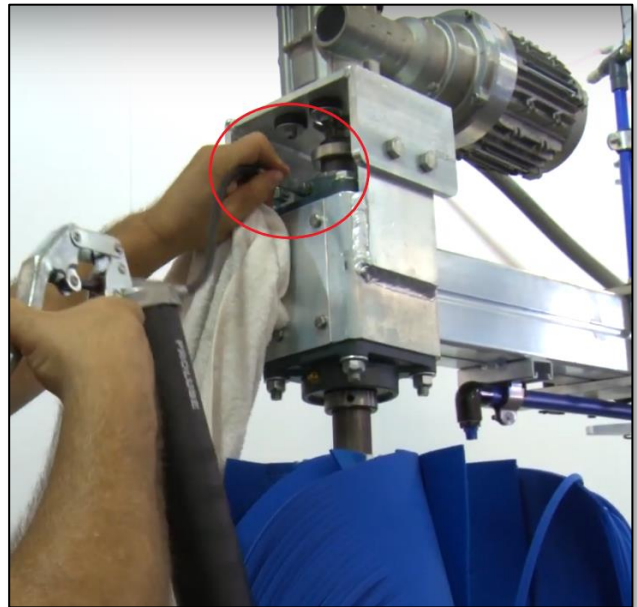

MAINTENANCE

FOR THE FIRST MONTH OF OPERATION CHECK ALL HARDWARE AND FITTINGS FOR TIGHTNESS EACH WEEK. PERFORM THIS INSPECTION TO THE SCHEDULE SHOWN BELOW AFTER THE FIRST MONTH OF OPERATION.

MONTHLY

1. Inspect all hardware and fittings for tightness.
2. Grease the brush hanger pillow block bearings. These are **pivotal bearings**, so they should be greased **monthly**. Use **two pumps of grease** for each pivotal bearing. Do not allow grease to come in contact with brush cloth (wipe the grease fittings clean after greasing).

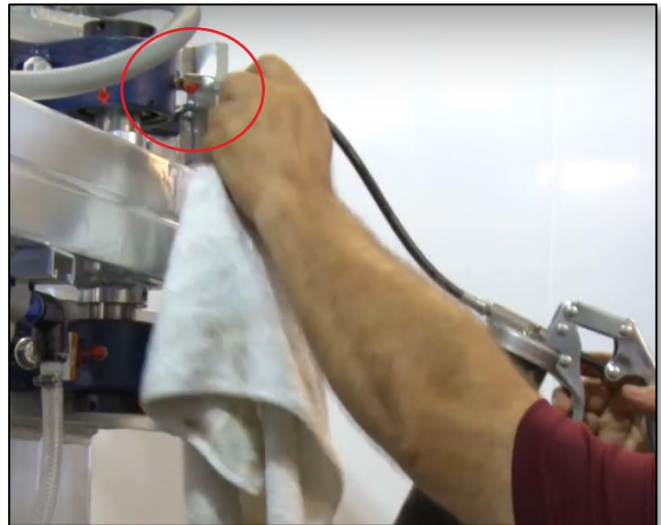
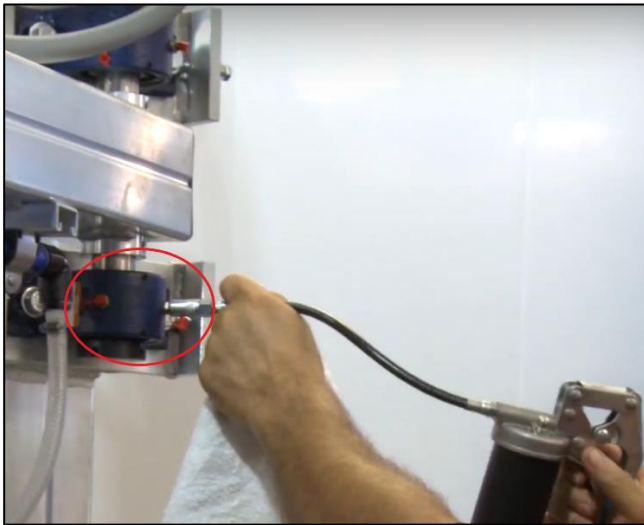

3. Inspect soap solution spray nozzles for wear. Replace as necessary.
4. Thoroughly clean the equipment and framework.

SEMI-ANNUALLY

1. Carefully inspect brush equipment cloth for wear and damage. Replace as necessary.

Replacement Parts

Exploded View – Hydraulic Attachment

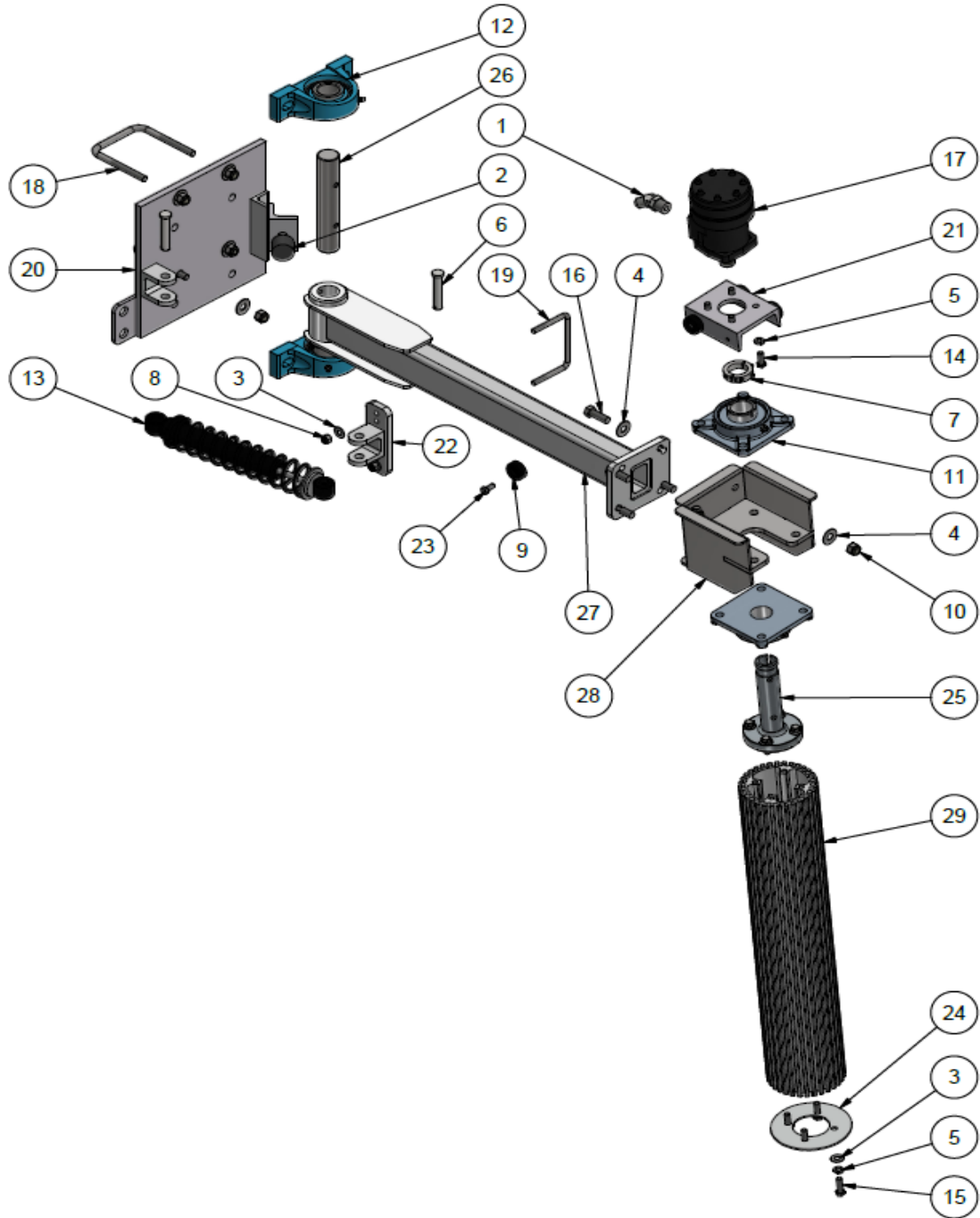

Exploded View – Hydraulic Attachment (Continued)

Hydraulic Top Mount Side Washer Attachment (18” – 35” Hubs) Parts List			
ITEM	QUANTITY	PART NUMBER	DESCRIPTION
1	2	10001775	Elbow 45° 6802-8-10 M JIC 1/2" x 7/8-14"
2	1	10002240	Rubber Stop 1.5in O.D. x 1.25in Length
3	10	10002656	Washer, Flat USS 3/8in
4	8	10002957	Washer, Flat USS 1/2in
5	12	10003066	Washer, Split Lock 3/8in SS
6	2	10003312	Clevis Pin 5/8in x 3in w/Bridge Pin
7	1	10003530	Collar 2pc Clamp 1-3/8in ID w/Set Screw
8	2	10004512	Nut, Hex Nylon-Lock 3/8-16 SS
9	4	10004629	Bolt, Hex 5/16-18 x 3/4 SS
10	4	10004704	Nut, Hex Nylon-Lock 1/2-13" SS
11	2	10005077	AMI Bearing 4 Bolt UCF208-24 Blk Bulk
12	2	10005079	AMI Bearing 2-Bolt Pillow Block 1-1/2"
13	1	10005110	Shock, Sonny's BFL100 Shock & Spring
14	4	10005402	Bolt, Hex 3/8-16in x 1in SS
15	8	10005648	Bolt, Hex 3/8-16 x 1-1/4 SS
16	4	10005675	Bolt, Hex 1/2-13 x 1-1/2 SS
17	1	10008079	Motor Hyd Parker1209 Char-Lynn3577 Bulk
18	2	10008258	U-Bolt Sq Bend 1/2-13 x 5in x 4-1/8in
19	1	10009738	U-Bolt, SQ Bend 3/8-16 x 3 x 4 3/8 SS
20	1	20000355	Plate, Face PS Rocker Brush
21	1	20001372	Torque Channel Aluminum
22	1	20001670	Shock Mount Bracket for Side Brush
23	4	20004602	Bumper, Button Small Black UHMW 9/32 ID
24	1	20010258	Unihub, Aluminum Retaining Plate
25	1	20014230	Spindle, Wrap Hydraulic BN
26	1	20016021	Shaft, TM Side Brush Attachment
27	1	20016022	Side Brush, Top Mount Arm Weldment
28	1	20017710	Side Brush, TM Hyd Bearing Box
29	1	20017734	Unihub, C-Channel 28in Machined 2.50 ID

Replacement Parts

Exploded View – Hydraulic Free Standing

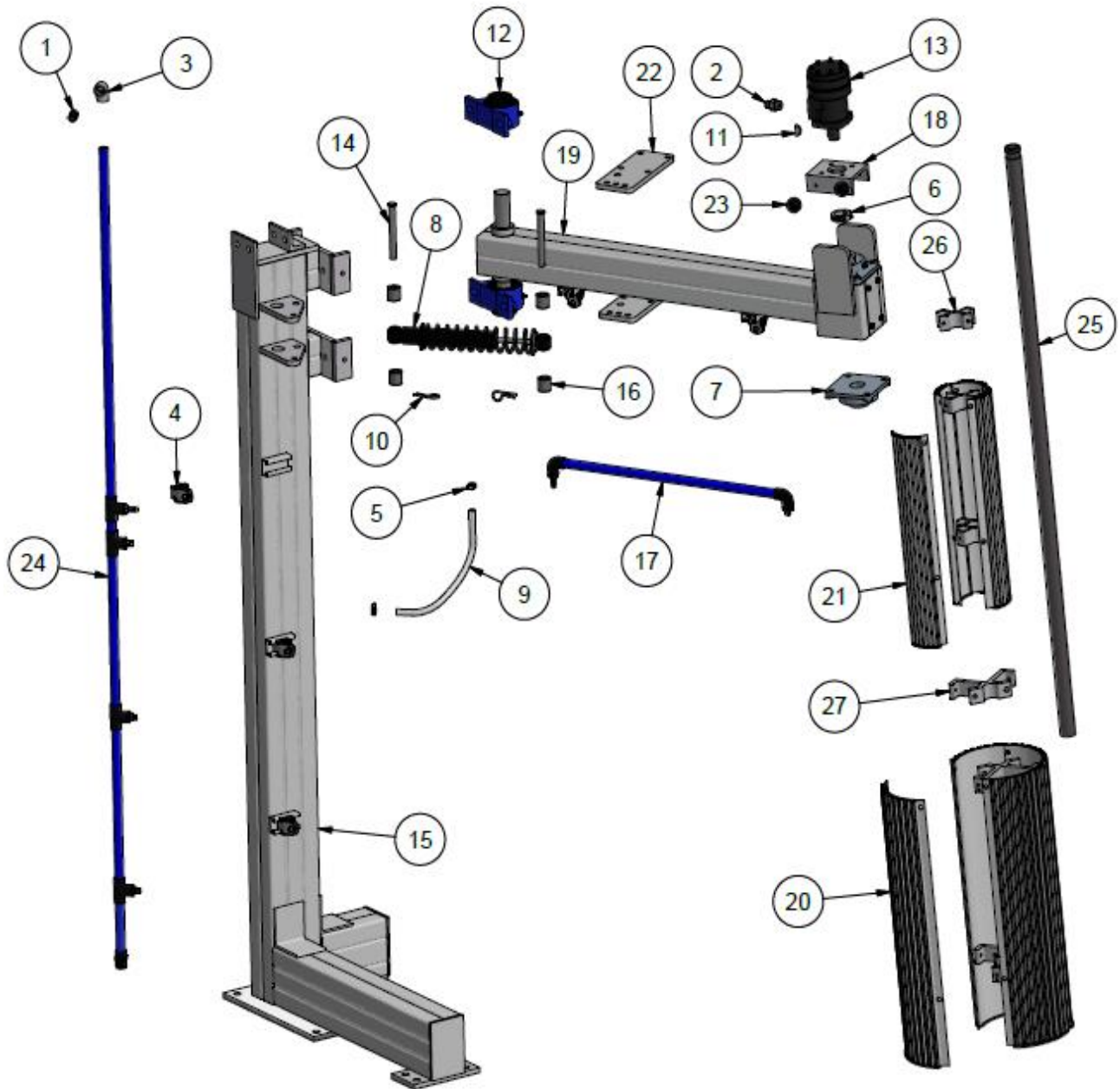

Exploded View – Hydraulic Free Standing (Continued)

Hydraulic Top Mount Side Washer Free Standing (50” – 63” Hubs) Parts List			
ITEM	QTY	P/N	DESCRIPTION
1	1	10000880	CONNECTOR 2404 M JIC 1/2IN X 1/2IN MPT
2	2	10000961	Connector 6400-8-10 JIC 1/2in x 7/8-14in
3	1	10002403	Elbow, 807-005 PVC80 1/2in Slip x 1/2 FPT
4	5	10002437	HZ, Cush-A-Clamp 200050 1/2in Pipe SS
5	2	10002508	Hose Clamp Mini 004M SS 5/8in Max Dia
6	1	10003530	Collar 2pc Clamp 1-3/8in ID w/Set Screw
7	2	10005077	AMI Bearing 4 Bolt UCF208-24 Blk Bulk
8	1	10005110	Shock, Sonny's BFL100 Shock & Spring
9	1	10005638-20	Clear Braided Hose 3/8in ID x 19/32in OD
10	2	10006482	Bridge Pin Wire .148 Stainless 22-06
11	1	10006558	Woodruff Key Half Moon 1/4in x 1-1/8in
12	2	10007357	Bearing 2-Bolt Pillow Block 1.5in Timken
13	1	10008079	Motor Hyd Parker1209 Char-Lynn3577 Bulk
14	2	10008362	Clevis Pin 5/8in x 5-1/2in Stainless Stl
15	1	20000340	Leg, SF50 SUV Brush PS Weldment
16	4	20000574	Spacer, SF Shock 1 1/4in x 3/4in Bore
17	1	20001270	Manifold, Water Side Wash Blue PVC 25in
18	1	20001372	Torque Channel Aluminum
19	1	20002743	Arm, VanBrush 50in PS 3° Weld w/ Shaft
20	4	20004428	Hubskin, 10in x 28in Long SF50 Weldment
21	4	20004435	6in Hub Skin 22in Long Weldment
22	2	20004540	Plate, Vanbrush Shockmount
23	4	20004602	Bumper, Button Small Black UHMW 9/32 ID
24	1	20006702	Manifold, Water SF50 Blue PVC
25	1	20007289	Shaft 62in Brush x 1-1/2in x 1in Bore
26	4	20011078	Spider, 6in Threaded
27	4	20011080	Spider, 10in Threaded

Replacement Parts

Exploded View – Electric Attachment

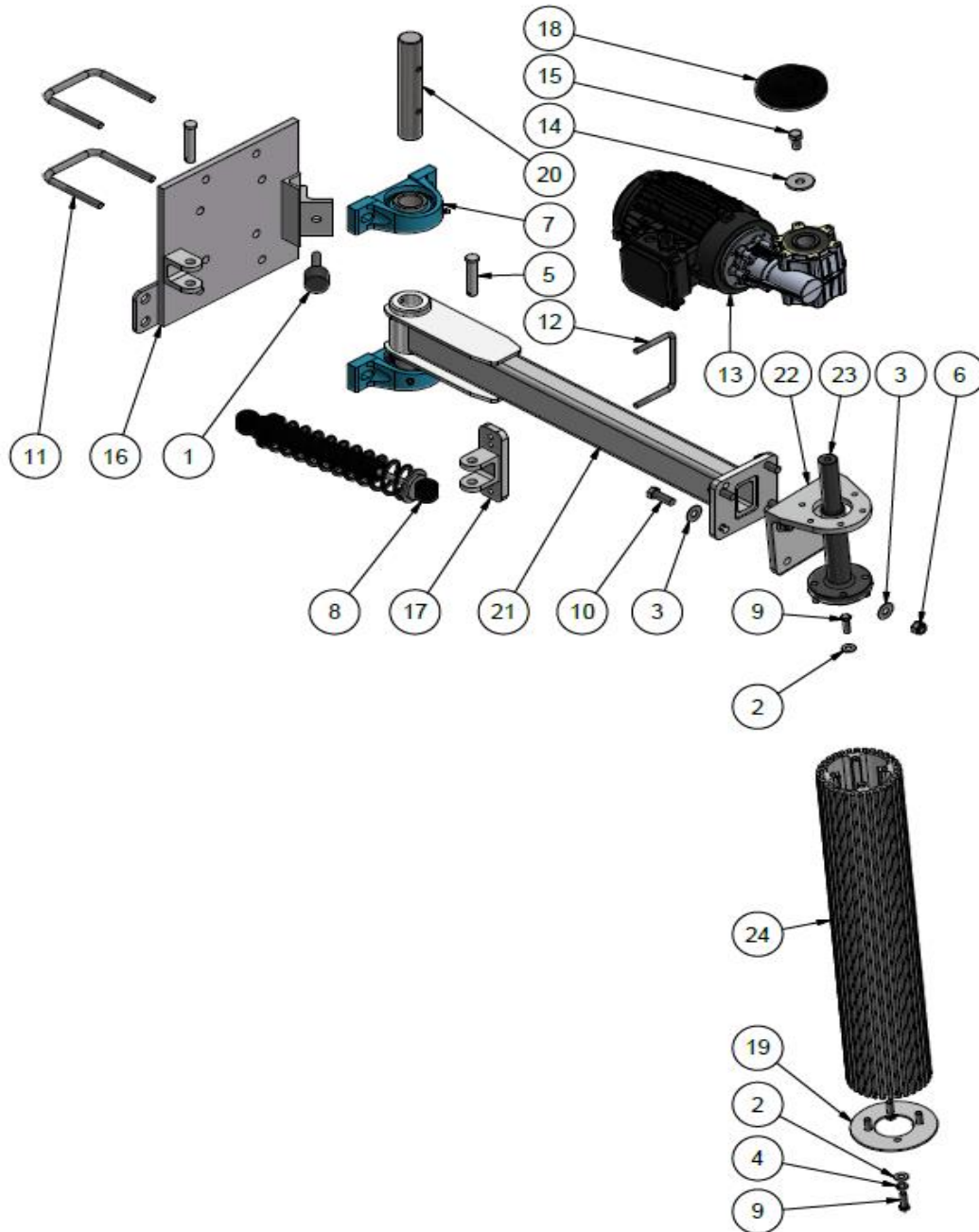

Exploded View – Electric Attachment (Continued)

Electric Top Mount Side Washer Attachment (18” – 35” Hubs) Parts List			
ITEM	QTY	P/N	DESCRIPTION
1	1	10002240	Rubber Stop 1.5in O.D. x 1.25in Length
2	8	10002656	Washer, Flat USS 3/8in
3	8	10002957	Washer, Flat USS 1/2in
4	8	10003066	Washer, Split Lock 3/8in
5	2	10003312	Clevis Pin 5/8in x 3in w/Bridge Pin
6	4	10004704	Nut, Hex Nylon-Lock 1/2-13" SS
7	2	10005079	AMI Bearing 2-Bolt Pillow Block 1-1/2"
8	1	10005110	Shock, Sonny's BFL100 Shock & Spring
9	8	10005648	Bolt, Hex 3/8-16 x 1-1/4 SS
10	4	10005675	Bolt, Hex 1/2-13 x 1-1/2 SS
11	2	10008258	U-Bolt Sq Bend 1/2-13 x 5in x 4-1/8in
12	1	10009738	U-Bolt, SQ Bend 3/8-16 x 3 x 4 3/8 SS
13	1	10011743	Flender Style TT Gearbox 16:1 Ratio 1HP
14	1	10012589	Washer, Fender 1/2 ID 1-3/4 OD 304 2B SS
15	1	10012590	Bolt, Hex 1/2 88 Stainless Steel
16	1	20000355	Plate, Face PS Rocker Brush
17	1	20001670	Shock Mount Bracket for Side Brush
18	1	20004545	Flender Style UHMW Black Motor Cover
19	1	20010258	Unihub, Aluminum Retaining Plate
20	1	20016021	Shaft, TM Side Brush Attachment
21	1	20016022	Side Brush, Top Mount Arm Weldment
22	1	20016372	Electric Motor Mount, TM Side Brush
23	1	20017711	Spindle, Top Mount Electric BN
24	1	20017734	Unihub, C-Channel 28in Machined 2.50 ID

Replacement Parts

Exploded View – Electric Free Standing

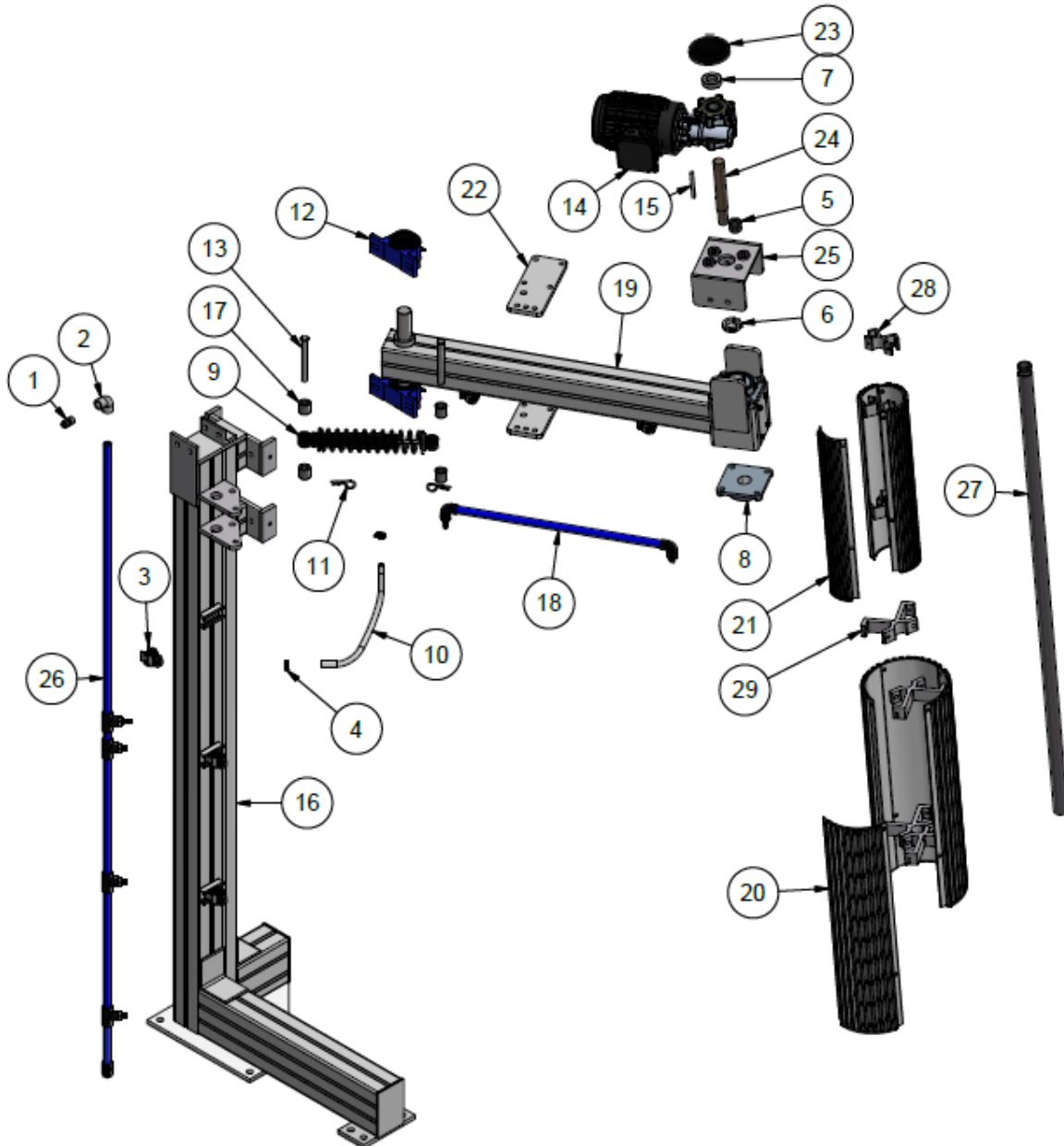

Exploded View – Electric Free Standing (Continued)

Electric Top Mount Side Washer Free Standing (50” – 63” Hubs) Parts List			
ITEM	QTY	P/N	DESCRIPTION
1	1	10000880	CONNECTOR 2404 M JIC 1/2IN X 1/2IN MPT
2	1	10002403	Elbow, 807-005 PVC80 1/2in Slip x 1/2 FPT
3	5	10002437	HZ, Cush-A-Clamp 200050 1/2in Pipe SS
4	2	10002508	Hose Clamp Mini 004M SS 5/8in Max Dia
5	4	10002706	Vibration Isolator Motor Mount Elastomer
6	1	10003530	Collar 2pc Clamp 1-3/8in ID w/Set Screw
7	1	10004349	Collar 1PC Solid 30mm ID 54mm OD SS
8	2	10005077	AMI Bearing 4 Bolt UCF208-24 Blk Bulk
9	1	10005110	Shock, Sonny's BFL100 Shock & Spring
10	1	10005638-20	Clear Braided Hose 3/8in ID x 19/32in OD
11	2	10006482	Bridge Pin Wire .148 Stainless 22-06
12	2	10007357	Bearing 2-Bolt Pillow Block 1.5in Timken
13	2	10008362	Clevis Pin 5/8in x 5-1/2in Stainless Stl
14	1	10011743	Flender Style TT Gearbox 16:1 Ratio 1HP
15	1	10011935	Key Stock 8mm X 8mm X 3.375in STL
16	1	20000340	Leg, SF50 SUV Brush PS Weldment
17	4	20000574	Spacer, SF Shock 1 1/4in x 3/4in Bore
18	1	20001270	Manifold, Water Side Wash Blue PVC 25in
19	1	20002743	Arm, VanBrush 50in PS 3° Weld w/ Shaft
20	4	20004428	Hubskin, 10in x 28in Long SF50 Weldment
21	4	20004435	6in Hub Skin 22in Long Weldment
22	2	20004540	Plate, Vanbrush Shockmount
23	1	20004545	Flender Style UHMW Black Motor Cover
24	1	20004623	Shaft Adapter 8.5in for Flender Style TopBrush
25	1	20004953	Bracket, Electric Conversion for Flender Style
26	1	20006702	Manifold, Water SF50 Blue PVC
27	1	20007289	Shaft 62in Brush x 1-1/2in x 1in Bore
28	4	20011078	Spider, 6in Threaded
29	4	20011080	Spider, 10in Threaded

Customer Service

Need more help?

For questions regarding **installation and/or operational issues and settings**, please contact Sonny's Tech Support at extension 234 or email at Sonnys-Support@SonnysDirect.com.

To order **replacement parts**, contact Customer Service at ext. 200, email us at CustomerService@SonnysDirect.com or visit us on the web at www.SonnysDirect.com.

Toll Free Main Line	800-327-8723
Local Number	954-720-4100
Customer Service	Option 3
Equipment Sales	Option 4
Technical Support	Option 5

Thank you for being a Sonny's car wash equipment owner!

From all of us here at



Warranty

SONNY'S ENTERPRISES, INC. FACTORY LIMITED LIFETIME WARRANTY

Equipment manufactured by SONNY'S ENTERPRISES, LLC. is warranted to be free from defect in material and workmanship. Welded metal framework and other non-moving, non-wearable fabricated metal components manufactured by Sonny's are warranted for the life of the equipment to the original purchaser. Fabricated metal wearable surface and moving components manufactured by Sonny's are warranted for a period of one (1) year to the original purchaser of the equipment.

All components assembled to Sonny's equipment that are manufactured by others are warranted by the appropriate manufacturer and subject to that manufacturer's limited warranty. Contact Sonny's for the specific information on other component manufacturer's warranty terms. All new cloth shipped with new Sonny's equipment is warranted for a period of one (1) year or 80,000, whichever occurs first.

This warranty is not assignable or transferable. The warranty period begins the first day following installation or 30 days from the original invoice date, whichever occurs first. The Seller's liability shall be limited to repair or replacement of materials found to be defective within the warranty period. In the event of repair or replacement this limited warranty is noncumulative. The Purchaser must supply the Seller with immediate written notice when any defects are found. The Seller shall have the option of requiring the return of defective material to establish the Purchaser's claim. Neither labor nor transportation charges are included in this warranty. Transportation damage claims are to be submitted to the carrier of the damaged materials.

This warranty is based upon the Purchaser's reasonable care and maintenance of the warranted equipment. It does not apply to any equipment which has been subject to misuse, including neglect, accident or exposure to harsh chemicals or chemicals that react violently with: water, organic acids (e.g. acetic acid), inorganic acids (e.g. hydrofluoric acid), oxidizing agents (e.g. peroxides), and metals (e.g. aluminum). Chemicals corrosive to: aluminum alloys, carbon steel, and other metals. Nor does it apply to any equipment which has been repaired or altered by anyone not so authorized by Sonny's. Further, the equipment must be properly installed with proper accuracy of all specified plumbing, electrical, and mechanical requirements. This warranty does not apply to normal wear and tear or routine maintenance components.

EXCEPT AS EXPRESSLY STATED HEREIN, SONNY'S SHALL NOT BE LIABLE FOR DAMAGES OF ANY KIND IN CONNECTION WITH THE PURCHASE, MAINTENANCE, OR USE OF THIS EQUIPMENT INCLUDING LOSS OF PROFITS AND ALL CLAIMS FOR CONSEQUENTIAL DAMAGES. THE LIMITED WARRANTY EXPRESSED HEREIN IS IN LIEU OF ALL OTHER WARRANTIES EXPRESSED OR IMPLIED. SONNY'S NEITHER ASSUMES NOR AUTHORIZES ANY PERSON TO ASSUME FOR IT ANY OTHER OBLIGATION OR LIABILITY IN CONNECTION HEREWITH.