



Buff-n-Dry™



Owner's Manual

Sonny's Enterprises, Inc.
5605 Hiatus Road
Tamarac, Florida 33321

TABLE OF CONTENTS

TABLE OF CONTENTS	2
SAFETY REQUIREMENTS	4
INTRODUCTION	6
PRODUCT FEATURES	7
PRODUCT SPECIFICATIONS	8
DIFFERENT CONFIGURATIONS	10
DIMENSIONS	11
INSTALLATION	13
Utilities Requirements	13
Water.....	13
Electrical.....	13
Compressed Air	14
Buff-n-Dry Installation.....	15
ATTACHING THE BRUSHES	20
Wick-A-Way HUSH	20
Top Brush.....	20
Side Wrap Brushes	23
ADJUSTMENTS AND TESTING	24
GENERAL OPERATION	27
Top Brush Operation	27
Retract Operation Top Brush	27
Wrap Around Washer Operation	27
Wrap Retract Operation	28
PREVENTIVE MAINTENANCE	29
DAILY.....	29
WEEKLY	29
MONTHLY.....	29

SEMI-ANNUALLY	29
WARRANTY	30
CUSTOMER SERVICE	31

SAFETY REQUIREMENTS

****WARNING****

1. All employees must be thoroughly trained in safe operation and standard maintenance practices. All employees must review this entire manual monthly.
2. Do not enter the wash tunnel when the equipment is operating. Death or dismemberment may occur.
3. Do not wear loose fitting clothing or jewelry around moving equipment. Do not allow any part of your body or other objects (including ladders, hoses or tools) to come in contact with moving equipment. Entanglement may result causing death or dismemberment.
4. Do not leave a ladder or any other items such as wash down hoses or tools in the wash tunnel while equipment is running. Vehicle damage and injury, including death, can occur.
5. Always exercise caution when walking (never run) through the wash tunnel as there may be slippery conditions. Be careful so you do not bump into or trip over equipment.
6. Only those employees specifically instructed and trained by the location management are permitted to enter the wash tunnel to perform inspections or maintenance. At least two qualified maintenance people must be present when performing equipment repairs or preventive maintenance.
7. Do not perform any maintenance or work on equipment unless you first perform Lock-Out Safety Precautions. All electrically powered equipment must have manually operated disconnects capable of being locked in the "OFF" position. Equipment that has been "locked out" for any reason must be restarted only by the person who performed the "lock out" operation.
8. When working on any equipment that is higher than your shoulders, always use a fiberglass ladder that is in good condition.
9. Do not attempt to repair or adjust any pressurized liquid or pneumatic part, hose, pipe or fitting while that equipment is in operation.
10. Electrical connections and repairs must be performed by a Licensed Electrician Only.
11. Emergency "STOP" buttons must be well marked and their location and proper use reviewed with all personnel. Any activated "STOP" button must be reset only by the person who activated it. Clear the wash tunnel of any people, ladders, hoses, tools and other loose items before restarting the equipment. An audible device must sound to warn people that the equipment is starting.

12. Do not operate any piece of equipment that requires safety covers with those covers removed or improperly installed. Do not operate any piece of equipment if any component of that piece is suspected to be defective or malfunctioning.
13. Store all cleaning and washing solutions and oils in a well-ventilated area. Clean up fluid spills immediately to prevent hazardous safety conditions. Be certain to follow all safety procedures on SDS Sheets for each chemical product used.
14. All electric systems in the wash tunnel equipped with a torque relief or overload should be checked and set at the minimum amount that will allow for proper functionality under normal washing conditions.
15. No unauthorized people should ever be permitted in the wash tunnel or near the equipment at any time.

* * *

!! CAUTION !!

When a piece of equipment must be in operation during inspection or maintenance, one qualified technician must stay at the power disconnect switch while another qualified technician performs the inspection or maintenance.

INTRODUCTION

This Manual contains information that is vital to the successful installation, operation and maintenance of your Sonny's vehicle washing equipment.

Please read, and understand, the full contents of this manual before installation and operation of the equipment. Keep this booklet in a location where it may be used for ongoing reference.

Should you have any questions on the operation or servicing of this equipment please contact:

**TECHNICAL SERVICES DEPT.
SONNY'S ENTERPRISES INC.
5605 Hiatus Road
TAMARAC, FLORIDA 33321**

TELEPHONE: 800-327-8723 FAX: 800-495-4049

Thank you for your confidence in Sonny's!



PRODUCT FEATURES

- Front-to-back drying performance.
- Available wraps feature a unique header design that provides further reach across the back of the vehicle while allowing for a complete retract to help material dry between vehicles.
- Automatic Truck Bed Retract option uses sonar to detect open truck beds and retract top brush and blowers to ensure labor-free reliable performance.
- Interchangeable material shams Velcro to the hub letting you change from one set to the other to ensure consistent wash quality. One set is working, while the next set is washed, dried and waiting to work.

PRODUCT SPECIFICATIONS

- Designed to occupy a maximum of 226" of tunnel length and a maximum of 186" width
- 4" x 4" or 4" x 6" aluminum frame and legs for stability and durability
- Solid UHMW Pivot Bearing with a grease fitting to increase smoothness of operation
- Double roller bearings on shaft
- 6" Unihub
- New Wrap header for complete retraction
- Electric brush drive motors are 1 HP each
- 1½" stainless steel pivot shaft
- 45 degree Restrict-O-Flex coupling for smooth operation
- Pneumatic retract controls standard
- Stainless steel brush hangers
- Brush tracks the contour of the vehicle using only a counterweight
- ½" city water connection

Tunnel Equipment Drying



TOP2K14 Buff-n-Dry™ Machine



Why Choose SONNY'S TOP2K14 Buff-n-Dry?

SONNY'S TOP2K14 Buff-n-Dry™ machine with lower height requirement is the ideal choice to wipe away residual water droplets and gently buff painted surfaces at high volume locations for a visibly better shine that customers will notice.

- **Low headroom installation** with two drying materials available to meet the specific environmental requirements of every wash. Available Wraps feature a unique header design that provides further reach across the back of the vehicle while allowing for a complete retract to help material dry in-between vehicles.
- **Automatic Truck Bed Retract** option uses sonar to detect open truck beds and retract top brush and blowers to ensure labor-free reliable performance. *See page 205 for details.*
- **Interchangeable material shams Velcro to the hub** let you change from one set to the other every couple of months to ensure consistent wash quality, or rightly for maximum performance at a high-volume location. One set is working, while the next set is washed, dried, and waiting to work.



LifeTime Limited
Warranty for
Generations to Come



FoundationFrame
Attachments to Grow
With Your Business

Specifications		Inches	Metric
Footprint Width		152in/188in*	3.9m/4.8m*
Height		128in/143in*	3.2m/3.6m*
Vehicle Clearance		90in	2.3m
Footprint Length	Top Brush Only	117in	3m
	With Tire Brush	188in	4.8m
	With Wraps	216in	5.5m
	With Wraps & Tire Brush	226in	5.74m
Electric		3-Phase 208-480V Per Motor	

*Dimension with
attached dryers

DIFFERENT CONFIGURATIONS

The Buff-n-Dry Machine can be configured with different equipment pieces to match your volume of business and the dimensions of your tunnel.

In addition to the entrance wraps, you can also include Mammoth Dryers on each side and also a Mammoth Dryer on the top. You can also include a Tire Seal Machine, if desired.



With Top Mammoth Dryer and Tire Seal Machine

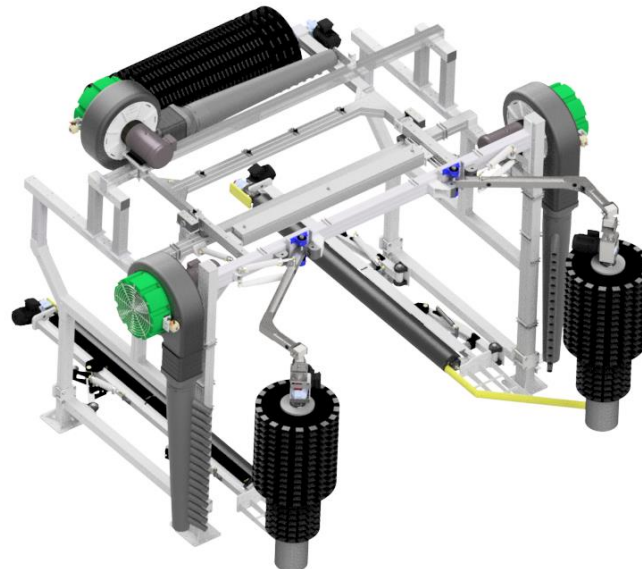

With Entrance Wraps, Top Mammoth Dryer, Side Mammoth Dryers and Tire Seal Machine

DIMENSIONS

1. Top Brush

2. Top Brush with Tire Seal

3. Top Brush, Tire Seal and Top Mammoth Dryer

(Side View)

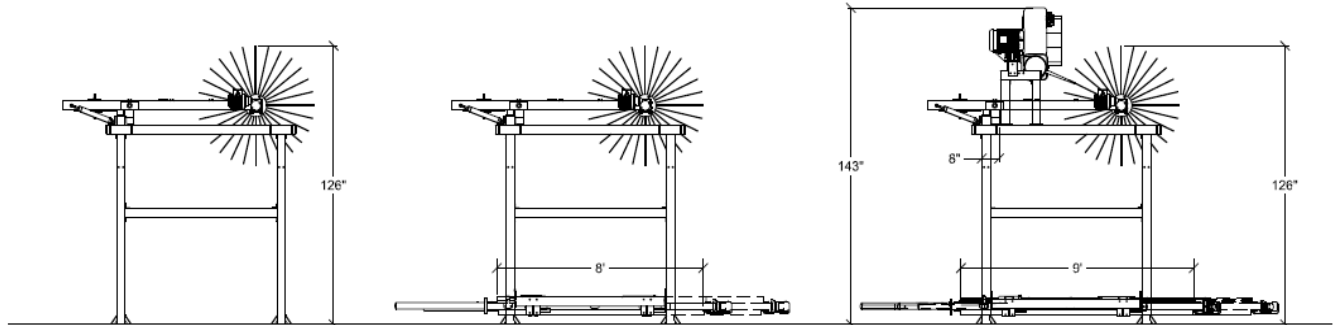

Car Travel →

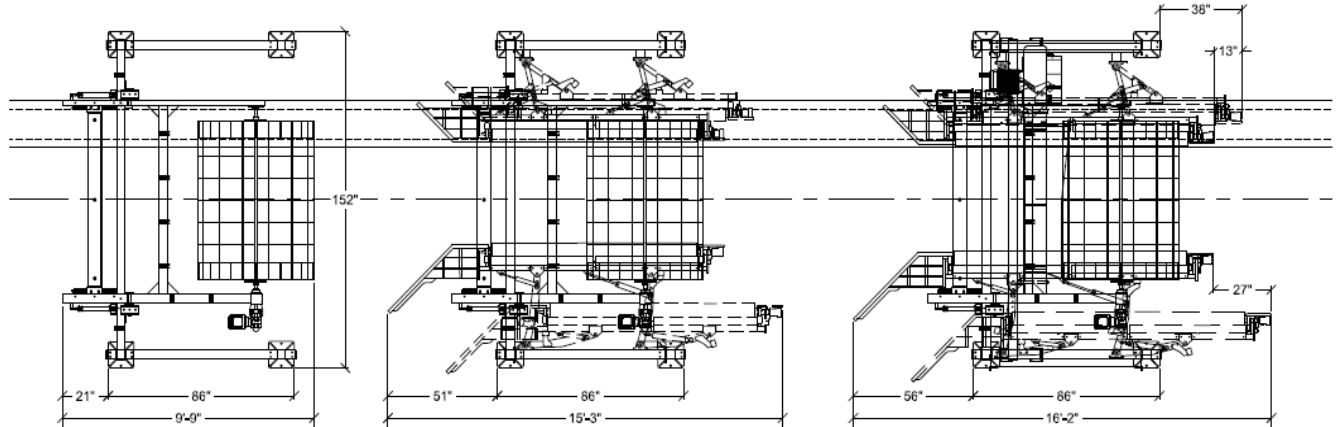

(Top View)

DIMENSIONS (Continued)

1. Top Brush, Tire Seal and Side Wraps

2. Top Brush, Tire Seal, Side Wraps, Top and Side Mammoth Dryers

(Side View)

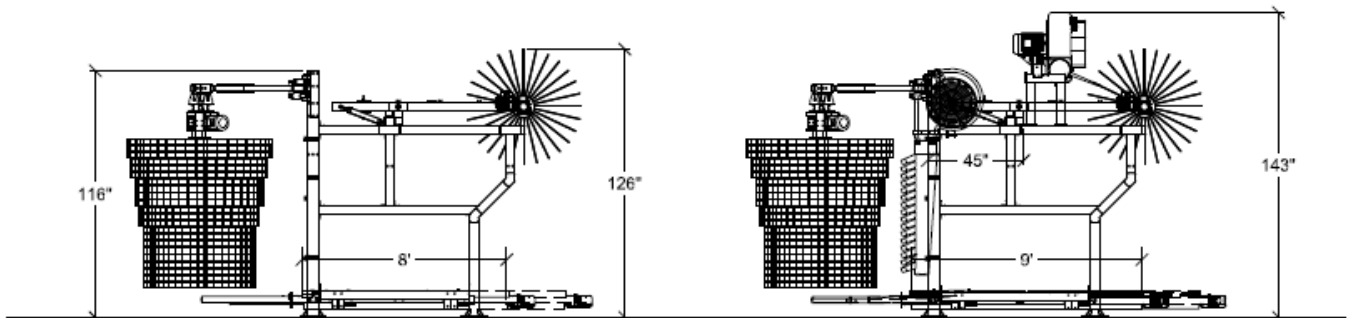

Car Travel →

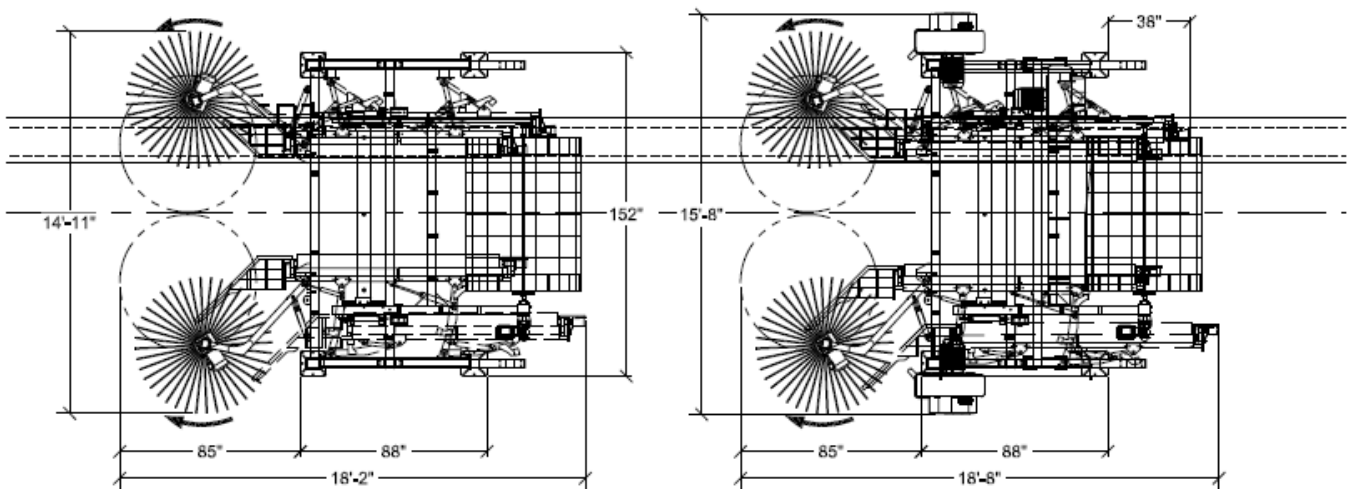

(Top View)

INSTALLATION

Utilities Requirements

UTILITIES INTERCONNECTION AND THE MATERIALS REQUIRED FOR INTERCONNECTION TO SONNY’S EQUIPMENT ARE THE RESPONSIBILITY OF THE CUSTOMER. PERFORM ALL TRADES WORK TO ALL APPLICABLE LOCAL AND NATIONAL CODES.

Water

- The Customer's Plumber is to provide and install a ½” city water line @60PSI (nominal) to the solenoid valve on the chemical distribution system for the Washer.

Electrical

- The Customer's Electrician is to provide and install single phase power (24 or 110 VAC as determined at time of order) from the Customer’s Controller system to the VFD feeding the brush.
- The Customer's Electrician is to provide and install single phase power from the remote push-button station through the tunnel equipment programmer to the supplied air solenoid valve on the Air Distribution Manifold for retract of both washers upon selective signal.
- Where applicable, the Customer's Electrician is to provide materials and install 208VAC or 230VAC or 460VAC, 3-phase, 60Hz power to the VFD panel from a properly sized three pole circuit breaker and motor starter with three thermal overloads.

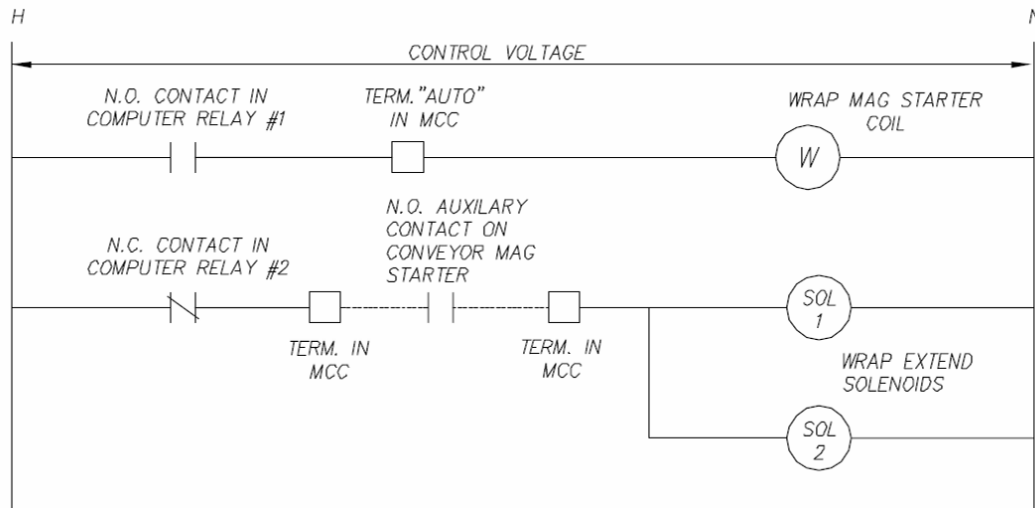

Compressed Air

- The Customer's Plumber is to provide and install a 1/2" compressed air line from the Air Compressor to the Air Distribution Manifold for the Retract functions.

TOP BRUSH PNEUMATIC DIAGRAM
TYPICAL EACH CYLINDER

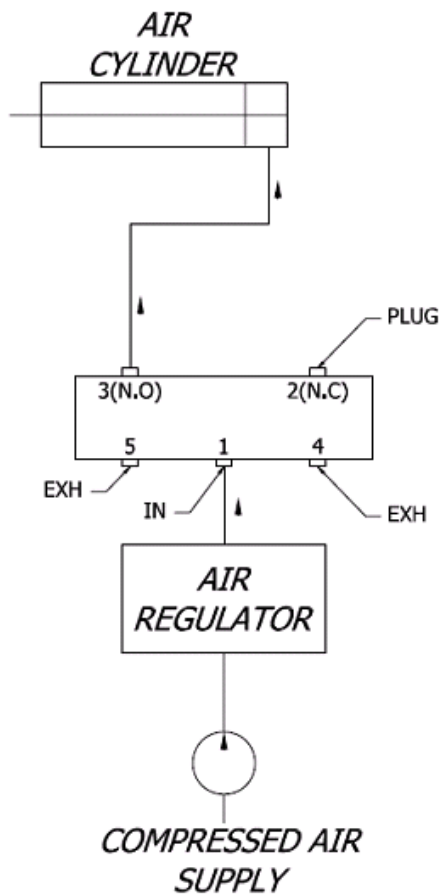

PROGRAMMABLE EXTEND INTERCONNECTION DIAGRAM
TYPICAL EACH CYLINDER

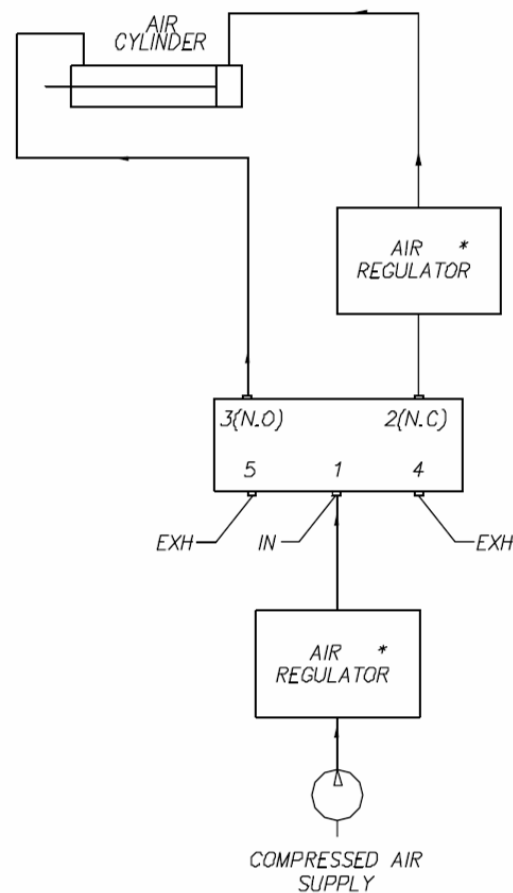

Buff-n-Dry Installation

Tools

1. Safety Glasses
2. Hearing/Ear Protection
3. ½” Drive Ratchet Set
4. Standard Combo Wrenches
5. 4’ Level
6. Electric Impact Wrench
7. 1” Hammer Drill with 5/8” Masonry Bit
8. Tape Measure
9. Sledge Hammer

Consumables

1. Anti-Seize Compound
2. Marine Grease

Work Force

Two (2) persons

Time (assuming no problems)

2.00 – 4.00 hours

Installation Steps

1. Determine where the Buff-n-Dry is to be installed (See **Figure #1** below and the tunnel layout drawings for your location).

Figure #1

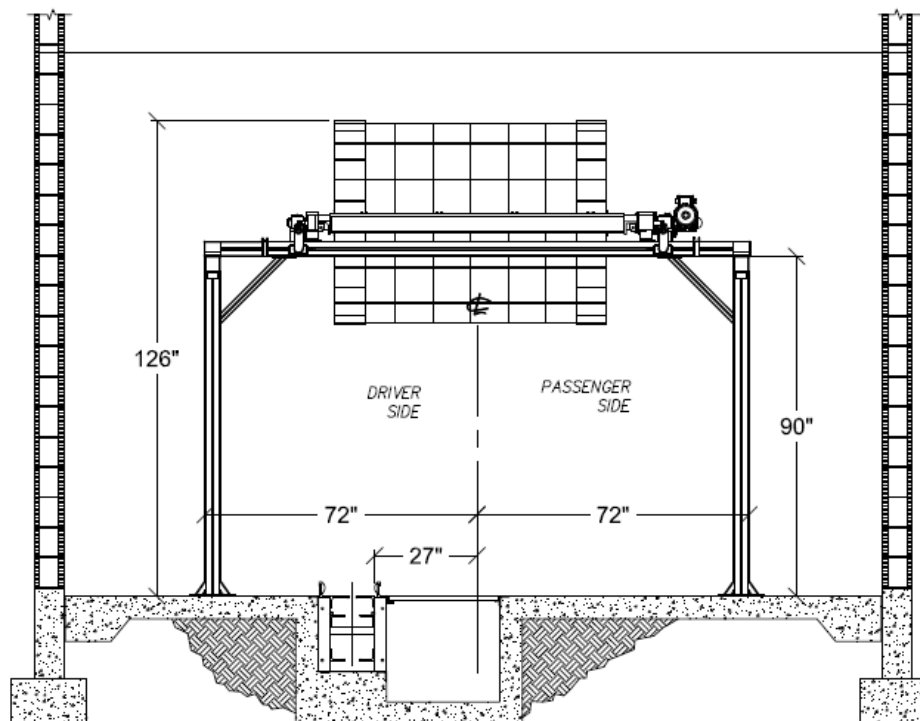
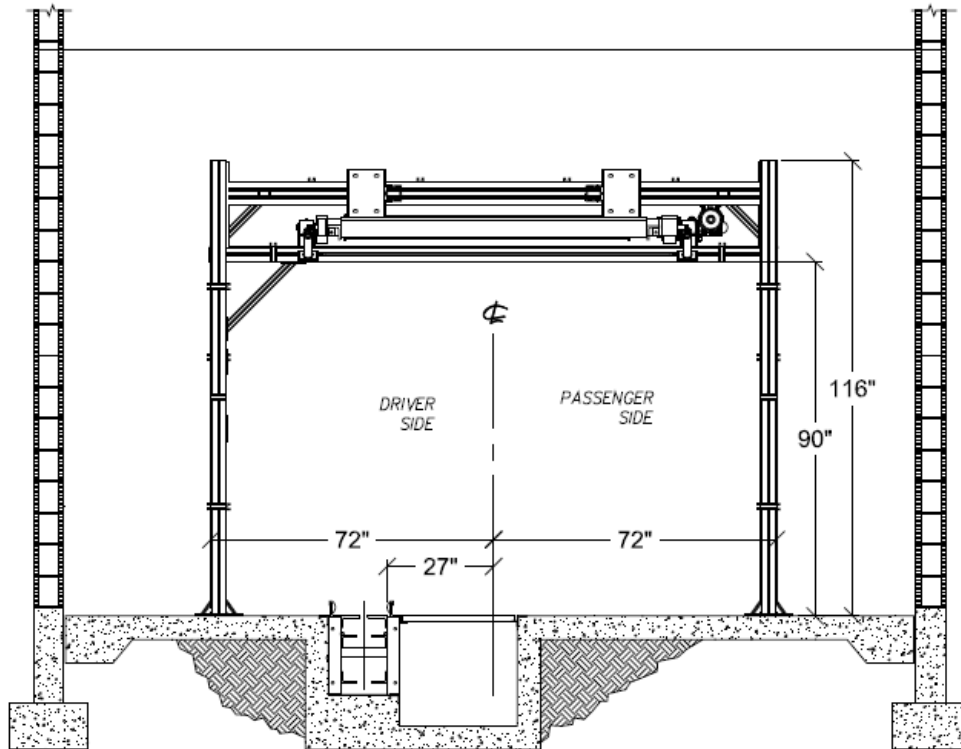

Figure #1 (Continued)



2. Sweep any debris from where the unit will stand.
3. Check all hardware and place a small amount of Anti-Seize Compound on each bolt.
4. Place the assembled frame side legs, cross beams and gussets in the area where the unit will be permanently located (with the brush counterweight toward the entrance of the car wash).
5. Check that the Passenger Side Brush hanger arm is longer than the Driver Side. If not, the frame is not positioned correctly.

6. With the interconnection hardware provided by Sonny's (boxed and attached to the assembly frame) join the legs, cross beams and gussets to the frame "finger tight".

Figure #2

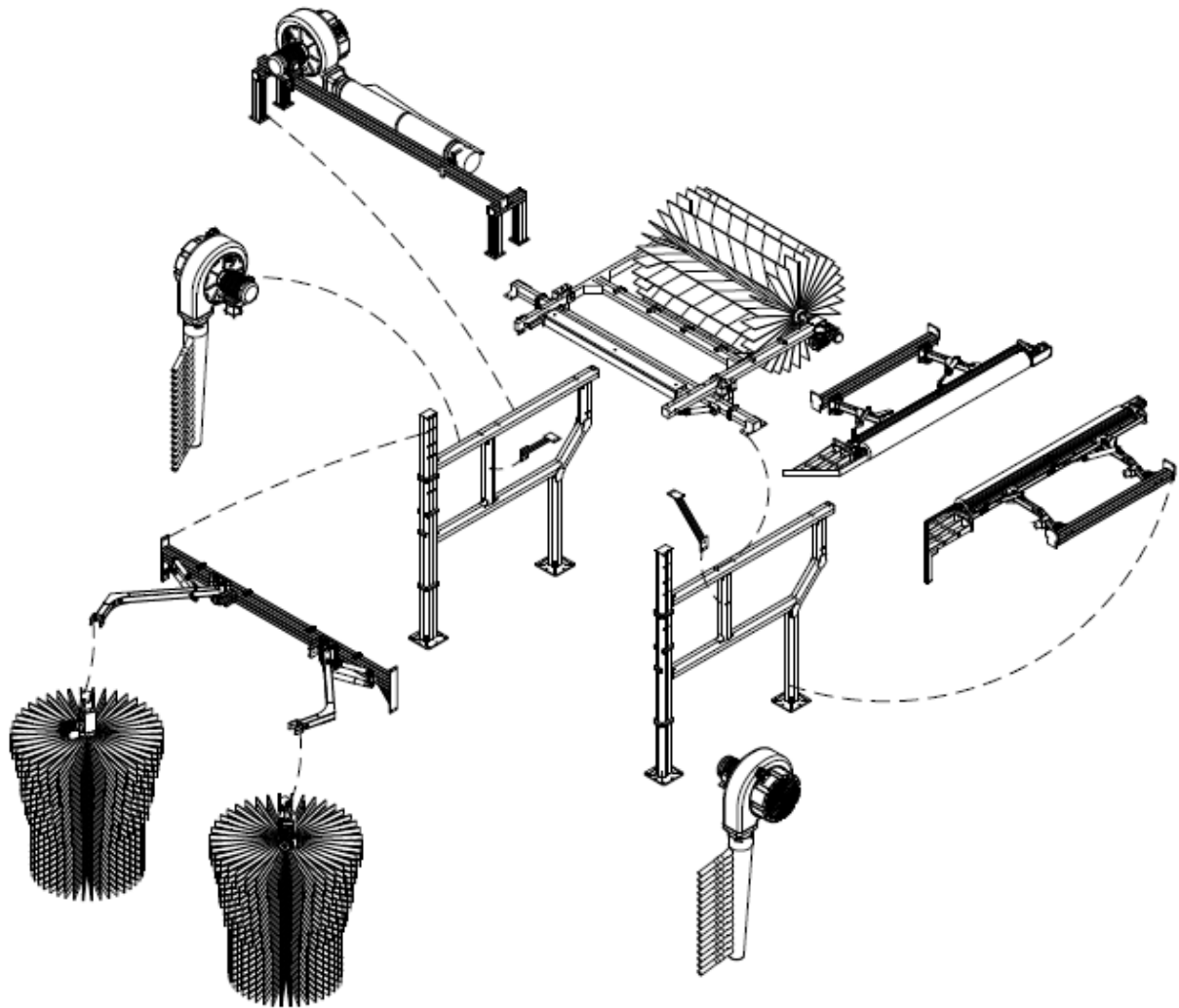

7. Place the unit per the dimensions shown in **Figure #1**. Be certain that the entrance and exit cross beams are level (shim mounting feet, if necessary) and that each of the 4 vertical legs are plumb. Tighten all hardware.
8. Level and square the frame with the centerline of the equipment (see **Figure #1** and the tunnel layout drawings for your location).

Note: Ensure the frame is correctly located before installing any anchors. Before anchoring the frame into position have a second person double check all measurements against your tunnel equipment layout drawings to ensure all measurements were performed correctly.

9. Using the hammer drill and hammer, place an anchor bolt in each corner.
10. Check each leg for plum and the frame for level, and then install the rest of the anchor bolts in each leg of the frame.
11. Install brush and counterweight assembly on the frame.
12. Check that the shock absorbers on each Brush Hanger do not "bottom out" in their fully extended position. If this occurs move the shock mounting position to a different hole on the mounting bracket to prevent a fully extended condition.

13. Move each brush hanger from the center of the wash tunnel so that it is parallel to vehicle travel. With each brush hanger in this position check that the hanger is level. Up or down adjustment of the brush hanger can be achieved by placing shim material under the brush hanger pillow block bearings.
14. Double check that the bottom pillow block bearing for each brush hanger is **EXACTLY** below the top pillow block bearing. This is necessary to provide light brush pressure against the side of the vehicle.
15. Mount the Brush Head, Shaft and Core assembly to each Hanger Arm.
16. Run and install the power to each brush.
17. Rotation of the Brushes is with vehicle travel. As viewed from the top of each Brush the DRIVER side turns **COUNTERCLOCKWISE** and the PASSENGER side turns **CLOCKWISE**. Rotation of the top brush is against vehicle travel. As viewed from the driver side the brush turns **COUNTERCLOCKWISE**. If brushes are rotating in the wrong direction, rewire for correct rotation.

Rotation speed of each Brush should be according to the **Operating Speeds Chart** in the **Adjustments and Testing** section of this manual.

18. Install the air retract cylinder and run the air lines to the manifold for the retract operation.

ATTACHING THE BRUSHES

Wick-A-Way HUSH

The hubs for the Top Brush and Side Wrap Brushes are delivered with the discs pre-attached on the hub. So, you just need to attach the individual brushes to each one of the discs.

The brushes are attached to each disc with Velcro patches.

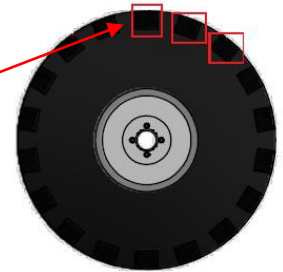

Top Brush

For your reference, here are the different parts that make up the Top Brush assembly:

ITEM	QTY	PART NUMBER	DESCRIPTION
1	8	10000514	Socket Cap 3/8-16 x 1-1/4"
2	8	10010782	3/8" 18-8 SS High Collar Lock Washer
3	33	10013263	Wick-a-Way Hush 29" Disk Assembly
4	6	10013287	Wick-a-Way Hush Double Buffer Pad
5	1	10013289	Wick-a-Way Hush Glued Disc Assembly
6	2	20010258	Unihub, Aluminum Retaining Plate
7	2	20010371	Top Brush, Ninja Shaft End Plate
8	1	20010382	Unihub, 4Key-Out 74" Machined 2.25 ID

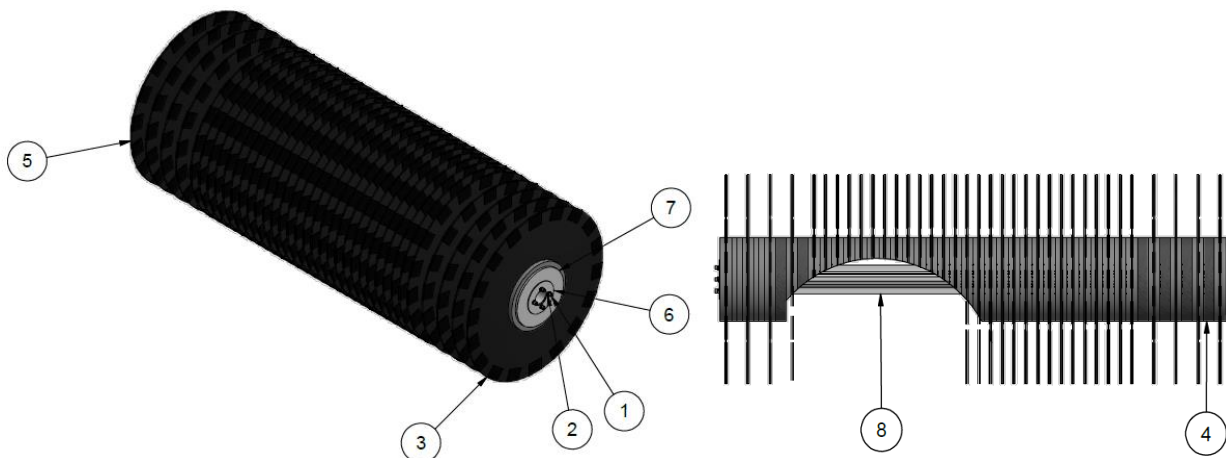

Note:

- The Velcro patches on the disc are referred to as the **Hook Side**.
 - The Velcro patches on the brush pads are referred to as the **Loops Side**.
1. Starting with the first disc on the hub assembly, attach a brush to each Velcro patch on the dish.

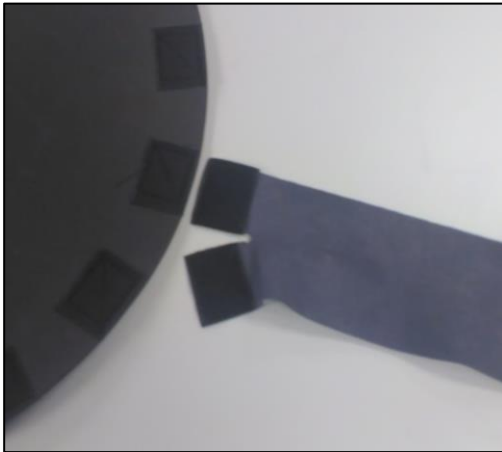

2. Fold the brush and attach one square of Velcro loops on the brush to each square of Velcro hooks on both sides of the disk.

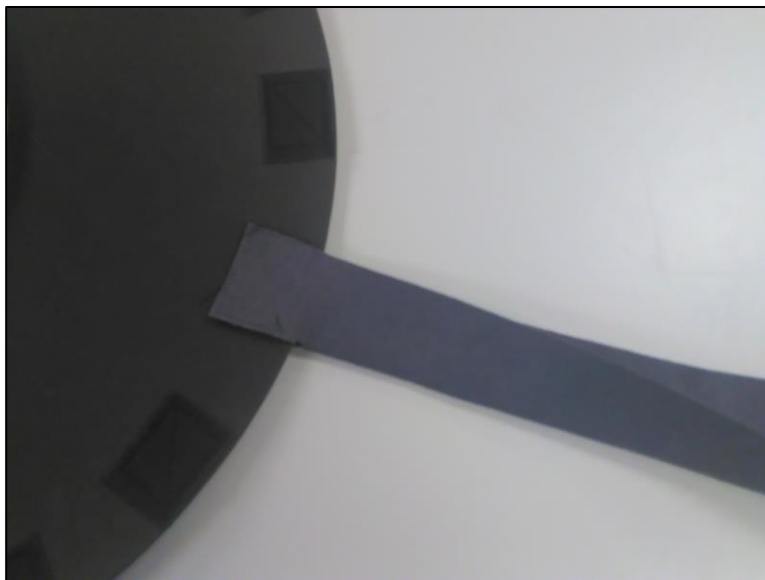

Note: When you fold the brush to attach it, it is **very important that the fold in the brush is facing the same direction as the rotation of the brush**. If the folded end is not facing in the same direction as the brush rotation, and the open end of the brush is, a scooping affect could cause the brush to begin retaining water, which you do not want.

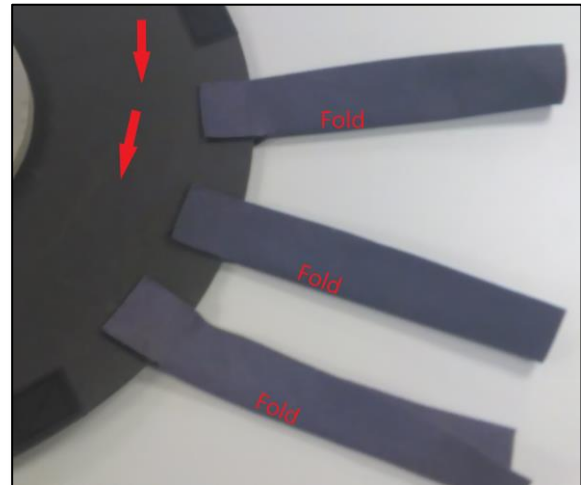
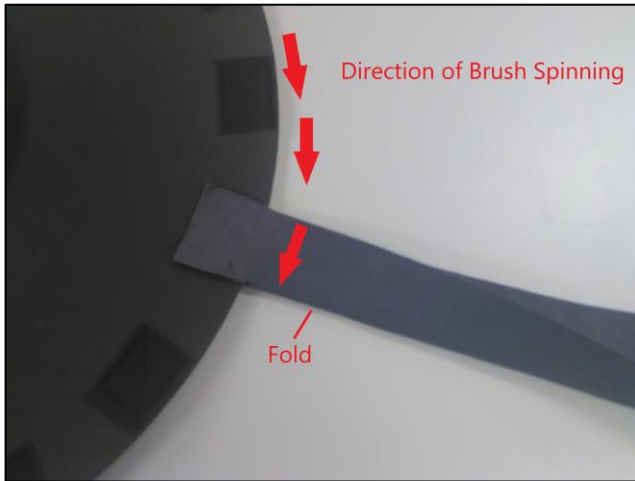

It is also very important that each Velcro patch on the brush is secured **squarely** against the Velcro patch on the disc. If the Velcro patch is not secured squarely, the exposed Velcro hooks could begin to catch the brush material, which can cause tangling or knotting of the brushes.

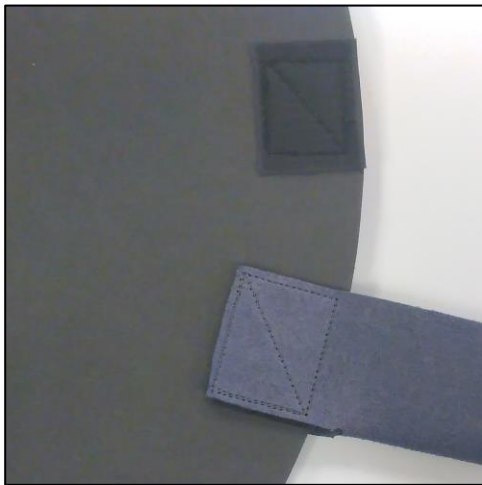

Do ✓



Don't ✗

Side Wrap Brushes

The brushes for the two Side Wraps are also attached via Velcro patches, in the same way as the Top Brush.

Remember: the folds in the brushes for the Side Wraps must face in the same direction as the rotation of the brushes.

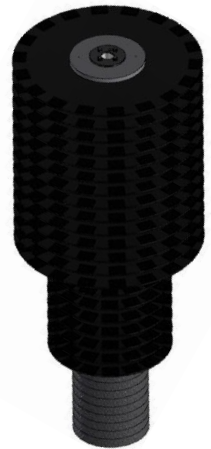

Driver Side Brush

Passenger Side Brush

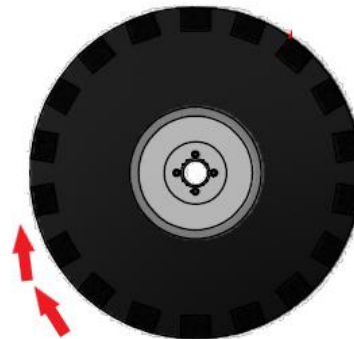
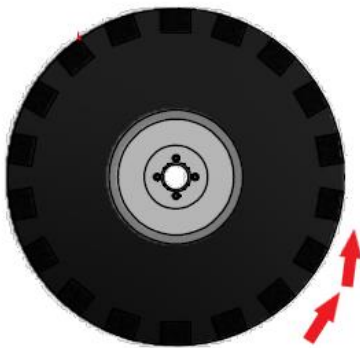

Vehicle Travel

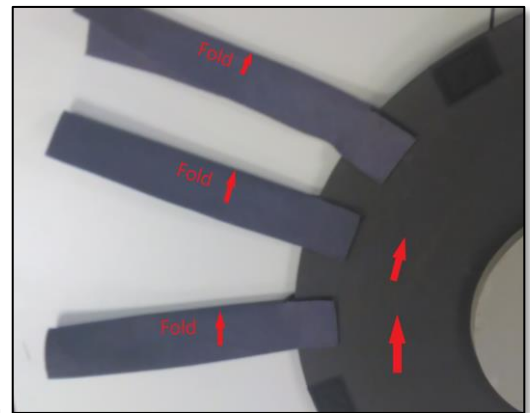
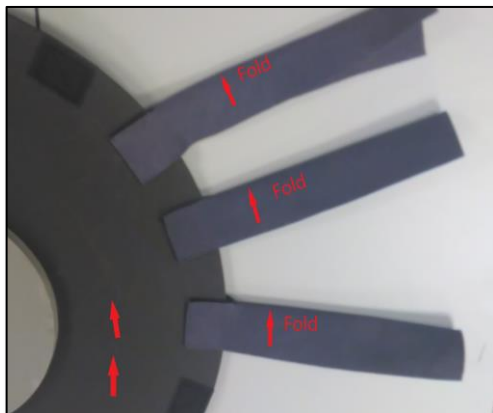

Vehicle Travel

ADJUSTMENTS AND TESTING

Adjust the Cleaning Pressure of the Top Brush

- Ensure the air solenoid is manually put in the wash position so there is no air pressure applied to the retract cylinder.
- Adjust the position of the counterweight so that when the counterweight is released the brush slowly moves downward.
- After initial adjustment manually activate and deactivate the air retract. When deactivated the brush should fall smoothly to the down position.
- Final adjustment of the counterweight can be accomplished while running test vehicles.
- Once adjusted properly the **cloth penetration should be about 3-4"** across the entire vehicle.

Note: If brush bounces too much, the counterweight has been adjusted too far out. Adjustment is easiest if made in small amounts, approximately 1/4" to 1/2" at a time.

Adjust Top Brush for Smooth Retract Operation

- To adjust the retract operation, the **air pressure regulator** should be adjusted for approximately **30PSI** in the **retract position**.
- The tunnel controller should be adjusted so that the brush is put into the wash position prior to the front of the car arriving at the brush. This will entail deactivating the retracts before the vehicle reaches the brush and setting the look ahead to check for the proximity of the next car.

Mechanical Adjustment of the Wrap Hanger Arms

- Install the unit so that the legs are plumb, the hanger arms are level when at the rest position and the mounting bearings are positioned perpendicular to floor (no pitch).
- The rest position will vary with operator preference and region.
- The two brushes should return to the rest position (middle of the tunnel) with no air pressure and no pitch to the bearings.

Buff and Dry Operating Speeds Chart Wrap Speed

Drying Speed	Retracted Speed	Wrap Air Pressure Driver	Wrap Air Pressure Pass
40-50 RPM	110 RPM (60 Hz)	0-5PSI	5-8 PSI

Table-1a

Top Brush Speed

Top Brush Drying Speed	Top Brush Retracted
40-45 RPM	110 RPM (60 Hz)

Table-1b

Note: The higher RPMs when retracted is to help the Top Brush stay dry

Two Solenoid valves, one for each retract, are recommended for 80 or more cars per hour.

To adjust the operation of the brushes without air pressure you may adjust the position of the pillow block bearings.

1. TO INCREASE THE PRESSURE ON THE SIDE AND BACK OF THE VEHICLE: Adjust the bottom pillow block bearing away from the center of the tunnel. Move in 1/8” increments at a time.
2. TO DECREASE THE PRESSURE ON THE SIDE AND BACK OF THE VEHICLE: Adjust the bottom pillow block bearing towards the center of the tunnel. Move in 1/8” increments at a time.

Cloth penetration should be about **3-4”** on the flat surface of the car. Each of the brushes should cover about two thirds of the back of the vehicle, overlapping in the center.

Speed and Torque Adjustment

Electric

- a. The speed can be adjusted on the VFD (Variable Frequency Drive).

Note: it is not recommended to run brushes above the RPMs listed in table 1a and 1 b

- To increase the speed, adjust the Hertz on the VFD to a higher number.
 - To decrease the speed, adjust the Hertz on the VFD to a lower number.
- b. The Overload on the Motor Starter protector(s) must be set at the lowest level to allow for operation.
 - c. Adjust the amps in accordance with the motor(s) name plate.

GENERAL OPERATION

The brushes on the unit need to spin anytime the conveyor is in operation.

Top Brush Operation

Brush rotation starts and stops with a signal from the Customer supplied Controller system.

BE CERTAIN THAT THE BRUSHES ROTATE AGAINST VEHICLE TRAVEL

With the brush rotating (against the direction of vehicle travel and at proper RPM) the vehicle's front hood contacts the brush and brush travels across the vehicle maintaining steady contact with the hood, roof and trunk of the vehicle.

Proper cloth penetration on flat vehicle surfaces should be **3-4"**. As the brush rounds corners, such as on windshields, the cloth penetration may be greater, but not deeper than half the distance to the aluminum brush core.

Retract Operation Top Brush

When there is no vehicle approaching the brush the tunnel controller will retract the brush from the wash position, toward the ceiling. This can also be set up in the controller to retract for the beds of trucks to avoid problems.

It is recommended that the brush be retracted for:

1. Sun visors mounted over the windshield.
2. Any racks mounted on the roof.
3. Rear wipers on Acura Integra's and Mazda RX-7's unless they are taped down.
4. Open bed pickup trucks.

Wrap Around Washer Operation

The brushes rotate in the same direction as vehicle travel. First the driver side brush and then the passenger side brush should come in just as the mirrors are approaching (**do not program the brushes to come in at the front of the vehicle**). The brushes move evenly down the sides of the vehicle, each drying one half.

As the rear of the vehicle approaches the brushes, they individually gear themselves around the rear fenders so that each brush dries one half of the vehicle rear vertical surfaces. As soon as the wraps meet in the middle of the vehicle they need to be retracted. The brushes should be set with zero look ahead or lookback feature.

NOTE: Proper cloth penetration on flat vehicle surfaces should be **3-4"**. As the wraparounds go around corners, such as fenders, cloth penetration may be greater, but not deeper than half the distance to the aluminum brush core.

Wrap Retract Operation

When selected by the Operator's remote Programmer push button station the wraparound brushes will retract from the center of the wash tunnel toward the tunnel outer walls. This can be done individually if one solenoid is used for each arm.

This is accomplished, when the push button is pressed, by completing an electrical circuit through the equipment Programmer to pass single phase power at the preset pulse count of the Programmer to the retract air solenoid valve. The air solenoid valve now opens and allows compressed air to pass through to the rod end port of each air cylinder causing the brush hangers to retract.

PREVENTIVE MAINTENANCE

DAILY

1. Check brush for proper operation, listening for any unusual noises from the equipment.
2. Inspect brush cloth for cuts, grease, or oil. Remove and repair, or replace, any cloth panel if any of these conditions are found.
3. Check retract and extend for proper operation, smoothness, and correct application pressure.

WEEKLY

1. Spray lubricant on the clevis pins on both ends of the retract cylinders.
2. Grease the brush shaft bearings. Do not allow grease to come in contact with brush cloth.
3. Drain water from the compressed air system's FRL and check lubricant level in the FRL.

FOR THE FIRST MONTH OF OPERATION CHECK ALL HARDWARE AND FITTINGS FOR TIGHTNESS EACH WEEK. PERFORM THIS INSPECTION TO THE SCHEDULE SHOWN BELOW AFTER THE FIRST MONTH OF OPERATION.

MONTHLY

1. Inspecting all hardware and fittings for tightness.
2. Grease the UHMW pivot bearings. Do not allow grease to come in contact with brush cloth.
3. Inspect the bumper stops for wear to ensure the air cylinders have not reached the end of their travel. If bumper stops are worn, they can be flipped to extend life.
4. Thoroughly clean the equipment and framework.
5. Clean the brush pads. Sonny's recommends cleaning your brush pads at least monthly. Wick-A-Way HUSH brush pads are attached to holders on the hub using Velcro, so they can be easily removed for cleaning in a washer/dryer.

SEMI-ANNUALLY

1. Carefully inspect brush equipment cloth for wear and damage. Replace, as necessary.
2. If fluid in reservoirs is contaminated drain, purge, and refill.

WARRANTY

SONNY'S ENTERPRISES, INC. FACTORY LIMITED LIFETIME WARRANTY

Equipment manufactured by Sonny's Enterprises, Inc. is warranted to be free from defect in material and workmanship. Welded metal framework and other non-moving, non-wearable fabricated metal components manufactured by Sonny's are warranted for the life of the equipment to the original purchaser. Fabricated metal wearable surface and moving components manufactured by Sonny's are warranted for a period of one (1) year to the original purchaser of the equipment.

All components assembled to Sonny's equipment that are manufactured by others are warranted by the appropriate manufacturer and subject to that manufacturer's limited warranty. Contact Sonny's for the specific information on other component manufacturer's warranty terms. All new cloth shipped with new Sonny's equipment is warranted for a period of one (1) year or 80,000, whichever occurs first.

This warranty is not assignable or transferable. The warranty period begins the first day following installation or 30 days from the original invoice date, whichever occurs first. The Seller's liability shall be limited to repair or replacement of materials found to be defective within the warranty period. In the event of repair or replacement this limited warranty is noncumulative. The Purchaser must supply the Seller with immediate written notice when any defects are found. The Seller shall have the option of requiring the return of defective material to establish the Purchaser's claim. Neither labor nor transportation charges are included in this warranty. Transportation damage claims are to be submitted to the carrier of the damaged materials.

This warranty is based upon the Purchaser's reasonable care and maintenance of the warranted equipment. It does not apply to any equipment which has been subject to misuse, including neglect, accident or exposure to harsh chemicals or chemicals that react violently with: water, organic acids (e.g. acetic acid), inorganic acids (e.g. hydrofluoric acid), oxidizing agents (e.g. peroxides), and metals (e.g. aluminum). Chemicals corrosive to: aluminum alloys, carbon steel, and other metals. Nor does it apply to any equipment which has been repaired or altered by anyone not so authorized by Sonny's. Further, the equipment must be properly installed with proper accuracy of all specified plumbing, electrical, and mechanical requirements. This warranty does not apply to normal wear and tear or routine maintenance components.

Except as expressly stated herein, Sonny's shall not be liable for damages of any kind in connection with the purchase, maintenance, or use of this equipment including loss of profits and all claims for consequential damages. The limited warranty expressed herein is in lieu of all other warranties expressed or implied. Sonny's neither assumes nor authorizes any person to assume for it any other obligation or liability in connection herewith.

CUSTOMER SERVICE

Need more help?

For questions regarding **installation and/or operational issues and settings**, please contact Sonny's Tech Support at extension 234 or email at Sonnys-Support@SonnysDirect.com.

To order **replacement parts**, contact Customer Service at ext. 200, email us at CustomerService@SonnysDirect.com or visit us on the web at www.SonnysDirect.com.

Toll Free Main Line	800-327-8723
Local Number	954-720-4100
Customer Service	Option 3
Equipment Sales	Option 4
Technical Support	Option 5

Thank you for being a Sonny's car wash equipment owner!

From all of us here at

